

# User Manual

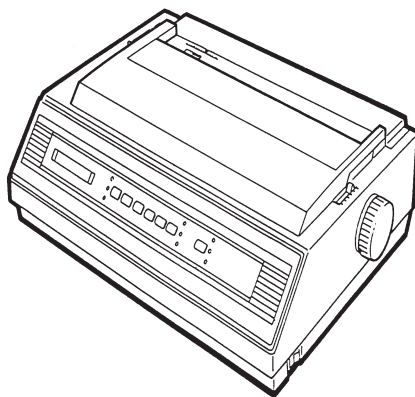



Compuprint  
914



# Compuprint Information

**Thanks** for choosing this printer.

*Your printer is a reliable working equipment that will be very useful in your daily job.*

*Our printers have been designed to be compact and respectful of the work environment. They offer a wide range of features and multiple functions that confirm the high technological level reached by the Compuprint S.p.A .*

*To maintain these printing performances unchanged in the long run, Compuprint has developed specific consumable accessories for each printer type (for example: ribbon cartridges for dot matrix printers, toner and OPC cartridges for laser printers, bubble ink jet cartridges for inkjet printers) that assure an excellent operation with high printing quality level reliability.*

*Compuprint recommends to use only its **original consumables with original packaging (identified by its holographic label)**. In this way, a proper use of the printer at quality level unreliability stated in the product characteristics can be assured. All typical usage problems related to not certificated consumables may be avoided, such as an overall quality print level degradation and ,often, the reduction of the product life due to the fact that the proper print heads working conditions, OPC cartridge and other printer parts are not assured.*

*Moreover, Compuprint does not only certify its consumables in terms of working conditions but also carefully controls their compliance with the international standard rules concerning:*

- *no cancerous materials;*
- *no inflammability of the plastic materials;*
- *other standards*

*Compuprint advices the customers not to use products for which the compliance to this safety rules are not warranted.*

*Finally seek your dealer or contact a Compuprint office and be sure that are provided you the original Compuprint consumables.*

# FCC Notes

This equipment has been tested and found to comply with the limits for a Class B digital device, pursuant to Part 15 of the FCC Rules. These limits are designed to provide reasonable protection against harmful interference when the equipment is operated in a commercial environment. This equipment generates, uses and can radiate radio frequency energy and, if not installed and used in accordance with the instruction manual, may cause harmful interference to radio communications. However, there is no guarantee that interference will not occur in a particular installation. If this equipment does cause harmful interference to radio or television reception, which can be determined by turning the equipment off and on, the user is encouraged to try to correct the interference by one or more of the following measures:

- Reorient or relocate the receiving antenna.
- Increase the separation between the equipment and the receiver to outlets on different circuits.
- Consult the dealer or an experienced radio/TV technician for help.

Changes or modifications not expressly approved by the party responsible for compliance could void the user's authority to operate the equipment. The use of a non-shielded interface cable with the referenced device is prohibited. The length of the parallel interface cable must be 3 meters (10 feet) or less. The length of the serial interface cable must be 15 meters (50 feet) or less..

## Canadian D.O.C. Radio Interference Regulation

This digital apparatus does not exceed the Class B limits for radio noise emission from digital apparatus as set out in the radio interference regulations of the Canadian Department of Communications.

Le présent appareil numérique n'émet pas de bruits radioélectriques dépassant les limites applicables aux appareils numériques de classe A prescrites dans le règlement sur le brouillage radioélectrique édicté par le ministère des communications du Canada.

## EEC Regulations

This equipment conforms to the EEC Directive 89/392 (the sound pressure, measured according to ISO 7779, does not exceed 70 dBA).

## ***How to Use This Manual***

This manual will help you to familiarize yourself with your printer so that you make the best use of its functions. Each operation is described in a separate chapter, for a quick and easy reference of the information that you need. If you are installing the printer, it is advisable to read the entire guide-book before beginning.

- Chapter 1:*** gives you information regarding to the printer features, appearance and technical characteristics.
- Chapter 2:*** provides instructions to install your printer.
- Chapter 3:*** provides you information about the use of your printer setup and paper handling.
- Chapter 4:*** provides maintenance information and error solutions.
- Chapter 5:*** describes each option of your printer.
- Appendix A:*** gives a detailed explanation of each command supported by this printer.
- Appendix B:*** gives you the character set tables.
- Appendix C:*** gives you information about the interface signals.
- Appendix D:*** it is a glossary about unfamiliar terms.
- Appendix E:*** it is an index for specific information

## ***Trademark Acknowledgments***

"IBM" and "IBM Proprinter XL" are trademarks of IBM Corporation. "EPSON" and "EPSON LQ 850-1050" are trademarks of EPSON Corporation.

The contents of this manual are subject to change without notice. All efforts have been made to ensure the accuracy of the contents of this manual. However, Compuprint can assume no responsibility for any errors of the manual and their consequences.

(c) Compuprint S.p.A., 1997

# Table of Contents

<b>Introduction .....</b>	<b>1</b>
Getting To Know Your Printer .....	1.2
Features .....	1.3
Unpacking Your Printer.....	1.4
Printers Parts .....	1.5
Printer Specifications .....	1.7
Software Driver Selection.....	1.10
<b>Installation .....</b>	<b>2</b>
Choosing a Suitable Location .....	2.2
Printer Assembly.....	2.3
Paper Stand Installation .....	2.3
Ribbon Cartridge Installation.....	2.3
Tractor Unit Installation.....	2.5
Tractor Unit Installation in Push Tractor Position .....	2.5
Tractor Unit Installation in Pull Tractor Position .....	2.7
Adjusting The Gap Between The Print Head And Platen .....	2.8
Turning The Printer On.....	2.9
Printing Your First Documents.....	2.9
Self-Test Printing .....	2.9
Carrier Movement Test .....	2.10
Host Computer Connection .....	2.11
Choosing The Connection .....	2.11
Parallel Connection .....	2.11
Serial Connection.....	2.11
Hexadecimal Printing.....	2.12
<b>Operation.....</b>	<b>3</b>
General Overview .....	3.2
Display Messages .....	3.2
Indicators.....	3.4
Function Keys .....	3.6
Buzzer .....	3.9
The Printer Setup .....	3.10
Entering Printer Setup.....	3.10
Moving within the Printer Setup .....	3.10
Function Selection Mode .....	3.10
Value Selection Mode .....	3.10
Leaving the Printer Setup.....	3.11
Setup Listing Printing .....	3.23
Paper Handling.....	3.24
Paper Specifications .....	3.24
Setting The Friction Release Lever.....	3.25
Loading Single Sheets (Friction Feed Mode).....	3.25
Inserting Fanfold Paper (Tractor Feed Mode).....	3.27
Paper Paths .....	3.28
Push Tractor Position .....	3.29

Pull Tractor Position .....	3.32
Loading Envelopes (Friction Feed Mode).....	3.35
Auto Paper Loading .....	3.36
Switching From Fanfold Paper to Single Sheet (Paper Park Function) .....	3.38
Tear Off Function .....	3.39
Tear-off operation.....	3.39
Tear-off position adjustment .....	3.40

## ***Maintenance* .....** **4**

Cleaning The Printer.....	4.2
Replacing The Ribbon Cartridge .....	4.2
Error Handling.....	4.4
Error Message Description .....	4.4

## ***Options* .....** **5**

Automatic Sheet Feeder (ASF) .....	5.2
Description .....	5.2
Unpacking.....	5.2
Installation .....	5.3
Paper Specifications.....	5.5
Paper Loading.....	5.6
ASF Removal.....	5.8

## ***Commands* .....** **A**

Introduction .....	A.2
General Overview .....	A.2
Command Summary .....	A.2
Commands Description .....	A.6

## ***Tables* .....** **B**

Character Sets .....	B.2
Character Set 1 (CS1).....	B.2
Character Set 2 (CS2).....	B.3
IBM PC Character Set (All Printable Character Table) .....	B.4
IBM National Variations.....	B.5
USA (CP 437).....	B.5
Multilingual (CP 850).....	B.6
Portugal (CP 860) .....	B.7
Canada/France (CP 863) .....	B.8
Denmark/Norway (CP 865).....	B.9
EPSON National Variations.....	B.10
Hexadecimal to Decimal Conversion Table .....	B.11

## ***Interface* .....** **C**

Parallel Interface.....	C.2
Serial Interface.....	C.5

## ***Glossary*.....** **D**



---

# ***Introduction***

---

This chapter introduces you to your new printer. After reading about its features, follow the unpacking procedure and then familiarize yourself with the printer parts. The printer specification table will give you a technical description of the printer's characteristics. This chapter concludes by informing you about software driver selection.

<b>Getting To Know Your Printer .....</b>	<b>1.2</b>
Features .....	1.3
<b>Unpacking Your Printer .....</b>	<b>1.4</b>
Printers Parts .....	1.5
<b>Printer Specifications .....</b>	<b>1.7</b>
<b>Software Driver Selection .....</b>	<b>1.10</b>

## Getting To Know Your Printer

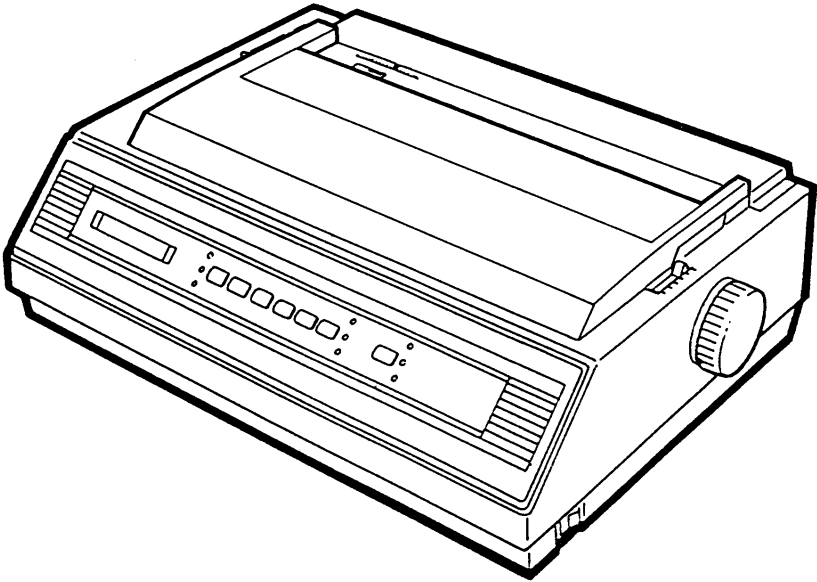

---

## Features

---

The following list details the capabilities of your printer:

- ❑ 24 needle printer with parallel or serial (option) interfaces
- ❑ High-speed printing 180 cps (at 10 cpi) and 216 cps (at 12 cpi) in Draft printing mode
- ❑ High-speed quality printing at 60 cps (at 10 cpi) and 72cps (at 12cpi) in Letter Quality printing mode
- ❑ High-resolution graphics printing (360 dpi (H) x 360 dpi (V))
- ❑ IBM Proprinter XL24/XL24E/XL24AGM and EPSON LQ850/1050 emulations.
- ❑ Easy print function selection (typestyles and pitches) and printer configuration via the operator panel.
- ❑ Automatic Paper Loading function (available in all paper loading mode except for pull tractor mode)
- ❑ Paper Park Function in Push tractor mode
- ❑ 1+3 copies printing capabilities
- ❑ An Automatic Sheet Feeder (option) that handles single sheets

## *Unpacking Your Printer*

Temporarily place the printer on a flat surface until a suitable permanent location can be chosen.

Check that everything is present and with no shipping damage.

Notify any damage to your supplier.

1. Take out the accessories from the box.
2. Identify the printer accessories.

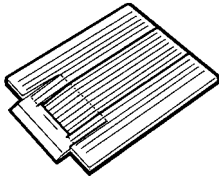

Paper Stand

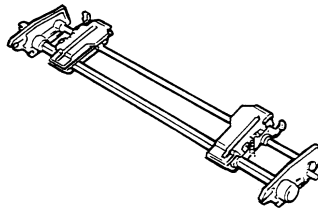

Tractor Unit

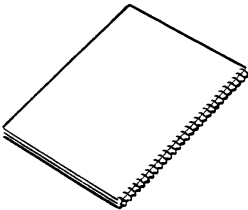

User Manual

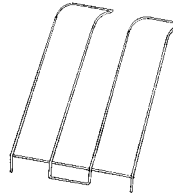

Fanfold Paper Guide

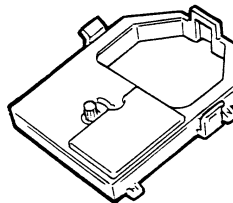

Ribbon Cartridge

**Printers Parts**

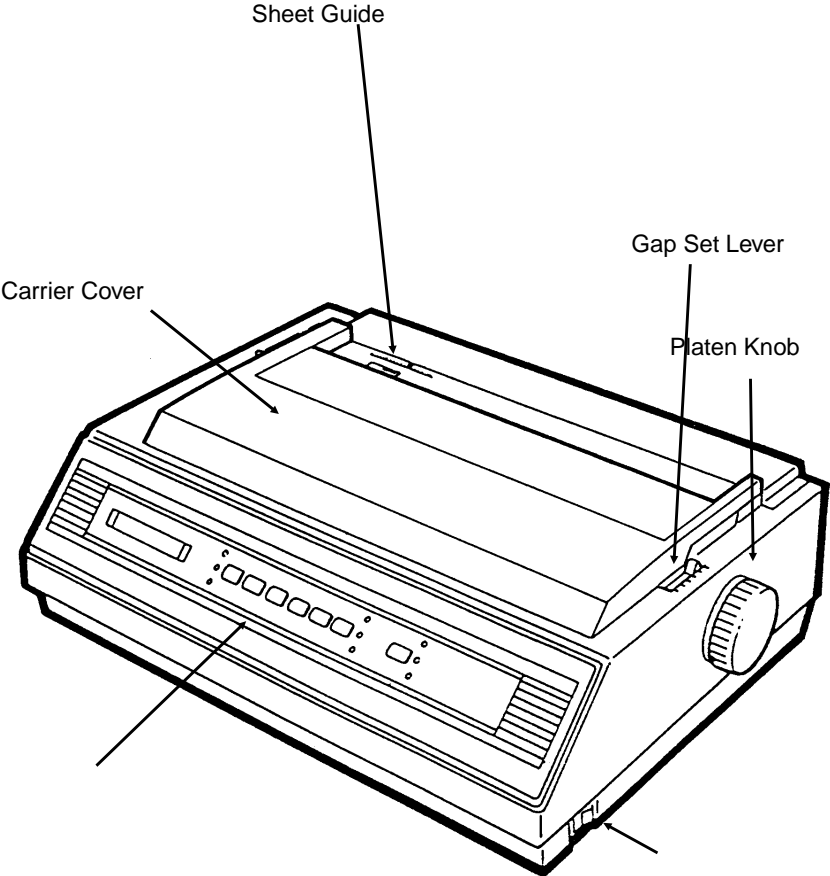

**Front View**

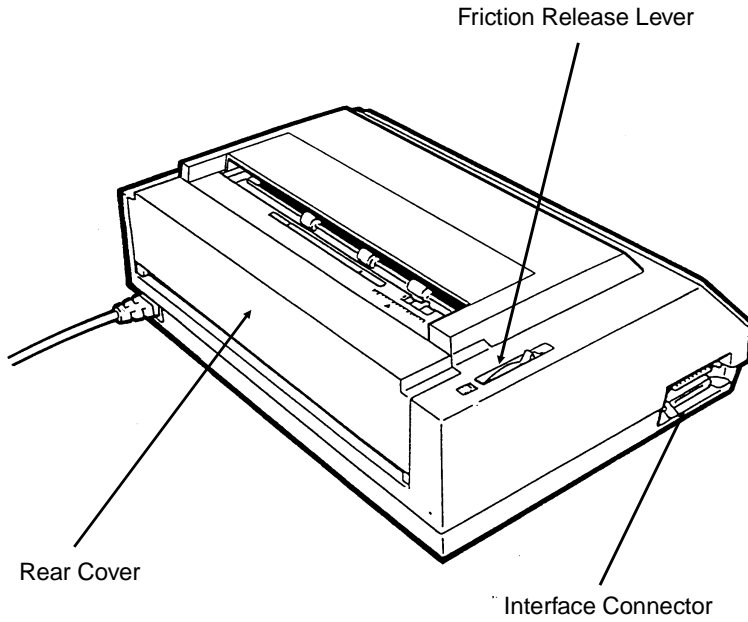

***Rear View***

# Printer Specifications

<b>Printing Method</b>	Bidirectional with logic-seeking
<b>Print Head Life</b>	100 million of characters
<b>Print Matrix</b>	
<i>Draft</i>	12 horizontal x 24 vertical at 10 cpi 10 horizontal x 24 vertical at 12 cpi
<i>Quality</i>	36 horizontal x 24 vertical at 10 cpi 30 horizontal x 24 vertical at 12 cpi
<b>Print Speed</b>	
<i>Draft</i>	180 cps at 10 cpi 216 cps at 12 cpi 135 cps at 15 cpi 154 cps at 17.1 cpi 180 cps at 20 cpi
<i>Letter Quality</i>	60 cps at 10 cpi 72 cps at 12 cpi 90 cps at 15 cpi 103 cps at 17.1 cpi 120 cps at 20 cpi
<b>Number of Columns</b>	136 at 10 cpi 163 at 12 cpi 204 at 15 cpi 233 at 17.1 cpi 272 at 20 cpi
<b>Line Feed Speed</b>	3 IPS (Inches per second)
<b>Character Set</b>	PC CS1 and PC CS2 IBM PC Character Set (All Printable Character Table) 15 EPSON National Character Sets 5 IBM National Character Sets: USA (CP437), Multilingual (CP850), Portugal (CP860), France/Canada (CP863), Denmark/Norway (CP865)
<b>First Printable Line</b>	9.6+/- 3 mm from the top margin

<b><i>Printing Attributes</i></b>	Double height Double s trike Double width Emphasized Italics Overscore Subscript Superscript Underline
<b><i>Resident Fonts</i></b>	Draft, Roman, Sans Serif, Courier, Prestige,Script, Gothic and Bold PS (Proportional Spacing). The <u>Bold PS</u> font prints out the proportional spacing only when <code>Proportional</code> value has been set in the printer Setup
<b><i>Paper Handling</i></b>	
<i>Paper Loading</i>	
Friction Feed Mode	width: 101 to 419 mm (4 to 16.5 inches) weight: 60 to 80 g/m2 40 to 60 g/m2 length: 127 to 304 mm (5 to 12 inches)
Tractor Feed Mode	width:101 to 406 mm (4 to 16 inches) weight:60 to 90 g/m2 single 40 to 60 g/m2 multipart
<i>Paper Type</i>	Single sheet or fanfold paper Multipart form - Envelopes
<i>ASF</i>	width: 139.7 to 216 mm (5.5 to 8.5 inches) weight: 60 to 90 g/m2 length: 139.7 to 356 mm (5.5 to 14 inches)
<b><i>Number of Copies</i></b>	1 original plus 3 copies
<b><i>Paper Thickness</i></b>	max. 0.28 mm Envelope: max.0.35 mm
<b><i>Parallel Interface</i></b>	Centronics type 8 bit parallel
<b><i>Serial Interface (option)</i></b>	RS-232C. protocols DTR, XonXoff

---

<b><i>Input buffer</i></b>	8 Kbytes (optional 32 Kbytes)
<b><i>Options</i></b>	Automatic Sheet Feeder (ASF) RS232C Serial Interface (dealer installable) 32 Kbytes Input Buffer (dealer installable)
<b><i>Power Supply (two versions)</i></b>	120 VAC +/- 10%, 60 Hz US. Power Cable 220-240 VAC +/- 10 %, 50 Hz Power Cable
<b><i>Power Consumption</i></b>	
<i>Operating</i>	55 W(Typ), 100W (Max)
<i>Standby</i>	9W
<b><i>Storage Environment</i></b>	
<i>Temperature</i>	-20° to 55° C
<i>Relative Humidity</i>	15 to 80 % (non condensing)
<b><i>Operating Environment</i></b>	
<i>Temperature</i>	10° to 40° C
<i>Relative Humidity</i>	20 to 80 % (non condensing)
<b><i>Standard Compliance</i></b>	UL 1950 D3 CSA C22.2 n.950 D3 FCC ( part 15) class B GS DIN/IEC 950/VDE 0805/11.91 VFG 243/91 46/92 DOC class.B (C.108 Canada gazette, Part II, vol 122, # 20) EN 55022 class B
<b><i>Noise Level</i></b>	55 dBA in Draft Mode 53 dBA in Quiet Mode
<b><i>Physical Dimensions</i></b>	
<i>Height</i>	132 mm (5.2 inches)
<i>Width</i>	570 mm (22.4 inches)
<i>Depth</i>	315 mm (12.4 inches)
<i>Weight</i>	8 Kg (17.6 lbs)

## Software Driver Selection

When you wish to configure your system using your application package, you should select the name of your printer, that is, Compuprint 914. If your printer name is not inserted in the list of the supported printers, select one of the printers shown below:

Printer Emulation	Printer Name
EPSON	EPSON LQ 850-1050
PROPRINTER	IBM Proprinter XL24
	IBM Proprinter XL24 E
PROPRINTER AGM	IBM Proprinter XL24 AGM

See in the "Appendix A" the detailed explanations of the control commands.

---

# Installation

---

After unpacking your printer, you need to find a suitable location for it; the first part of this chapter provides criteria for making this decision. You can then begin the installation process by assembling the printer and its accessories. You should next print a test document to verify that the printer is functioning correctly. Finally, you can connect the printer to the host computer.

<b>Choosing a Suitable Location .....</b>	<b>2.2</b>
<b>Printer Assembly .....</b>	<b>2.3</b>
Paper Stand Installation.....	2.3
Ribbon Cartridge Installation.....	2.3
Tractor Unit Installation .....	2.5
Adjusting The Gap Between The Print Head And Platen .....	2.8
Turning The Printer On .....	2.9
Printing Your First Documents .....	2.9
<b>Host Computer Connection.....</b>	<b>2.11</b>
Choosing The Connection .....	2.11
Parallel Connection .....	2.11
Serial Connection .....	2.11
Hexadecimal Printing.....	2.12

## Choosing a Suitable Location

Consider the following points when you choose the location for your printer:

- ◆ The distance between the printer and the host computer must not exceed the length of the interface cable;
- ◆ The location must be sturdy, horizontal and stable;
- ◆ Your printer must not be exposed to direct sunlight, extreme heat, cold, dust or humidity (see "Printer Specifications", in chapter 1);
- ◆ You need an AC power outlet compatible with the plug of the printer's power cord. The voltage of the outlet must match the voltage shown on the printer's Name Plate;

Additionally, you must make sure that when you install the printer in the selected location, there are sufficient clearances on all sides for easy operation. The required space is shown below (unit: mm (inch)):

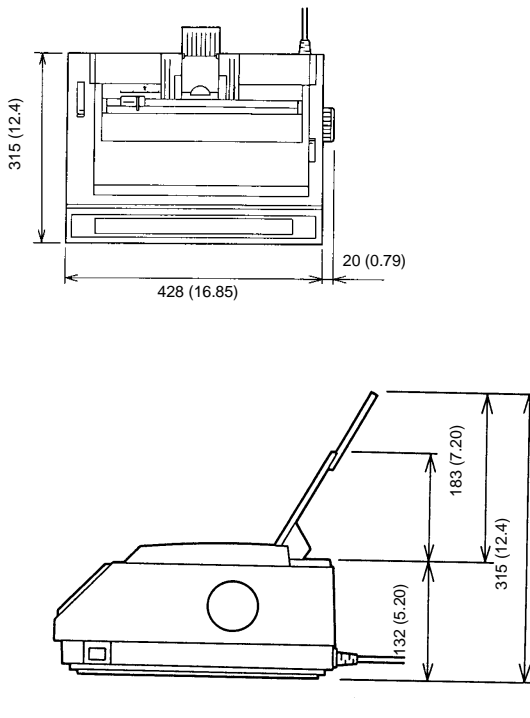

## Printer Assembly



---

*Make sure that the printer is turned OFF.*

---

### Paper Stand Installation

---

1. Locate the paper stand among the accessories.

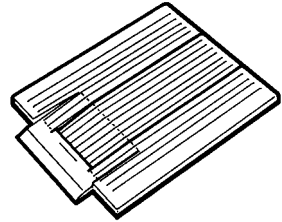

2. Install the paper stand in the printer.

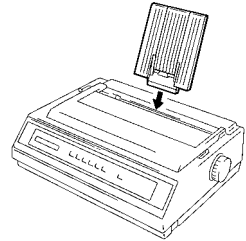

### Ribbon Cartridge Installation

---

1. Locate the ribbon cartridge among the accessories.

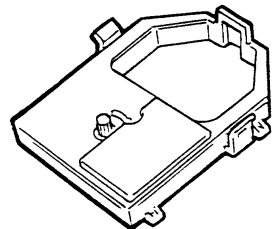

2. Remove the carriage cover, then manually move the carriage to the center of the printer. Set the gap set lever to its rearmost position 6 to provide the maximum distance between the print head and the platen for smooth installation (see forward "Gap Adjustment Between The Print Head And Platen", in this chapter..)

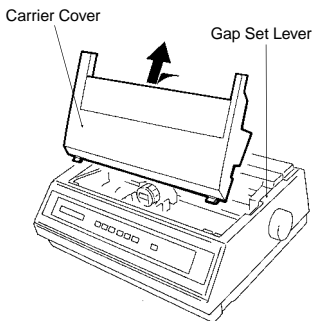

3. Before installing the ribbon cartridge, turn the ribbon winding knob in the direction of the arrow to take up slack in the ribbon.

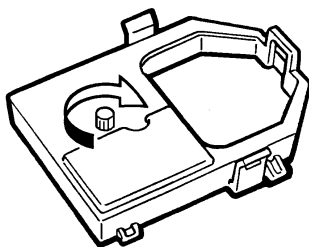

4. Position the ribbon cartridge on the carriage and push it down following the direction of the arrow. Rotate the ribbon winding knob again to take up slack in the ribbon. Manually move the carrier horizontally to ensure that the ribbon winding knob rotates properly

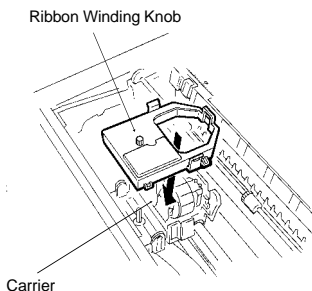

- Return the carrier cover on the printer. Set the gap set lever to proper position according to the paper thickness you are using. See "Adjusting the Gap Between the Print Head and Platen" described in this chapter.

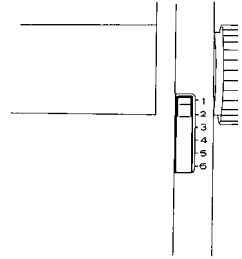

## ***Tractor Unit Installation***

---

Find the tractor unit among the accessories.

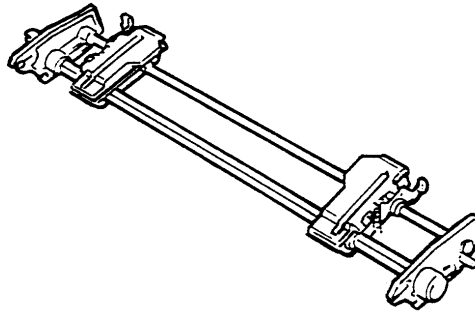

### ***Tractor Unit Installation in Push Tractor Position***

- Open the rear cover.

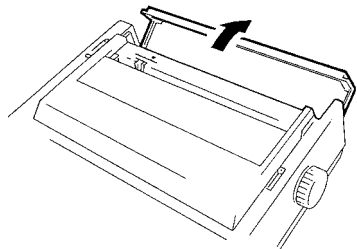



---

***Move the left tractor to the leftmost position before installing the tractor unit***

---

2. Install the tractor unit in the rear of the printer.

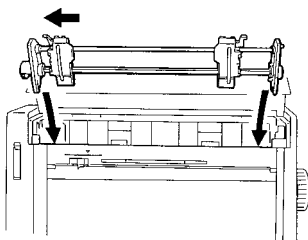

3. Press the tractor unit downward until it clicks. Turn the platen knob to ensure that the tractor pins also rotate.

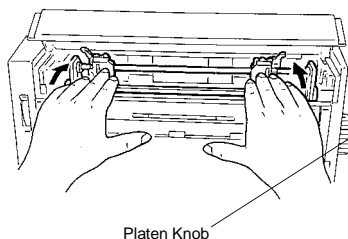

4. The push tractor unit can be easily removed by lifting it up.

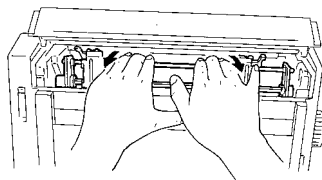

## Tractor Unit Installation in Pull Tractor Position

1. Remove the carriage cover.

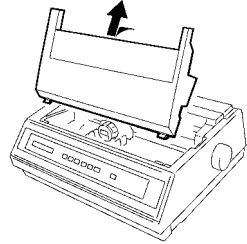

2. Place the tractor unit onto the printer with the gears of the tractor unit facing down. Move the left tractor to the leftmost position before installing the tractor unit.

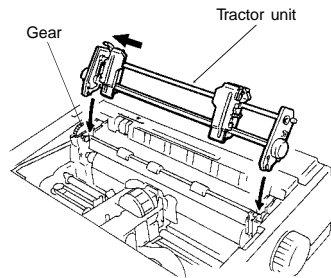

3. Press the tractor unit downward until it clicks. Turn the platen knob to ensure that the tractor pins also rotate. Install the carriage cover.

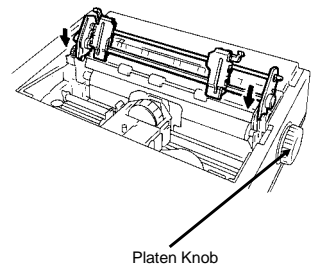

- 4. The tractor pull tractor unit can be easily removed by pressing it rearward.

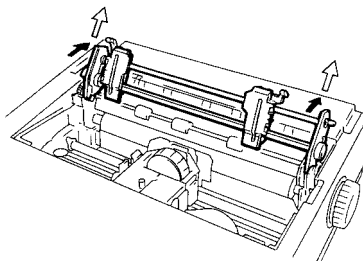

## ***Adjusting The Gap Between The Print Head And Platen***

---

Adjusting the gap between the print head and platen allows the optimum print quality. The gap set lever is located at the right front side of the printer. When the gap set lever is moved forward, the gap becomes wider. When it is moved backward, the gap becomes narrower. Before printing, select the gap set lever position as follows:

- |                                |  |
|--------------------------------|--|
| <b><i>Position 1 :</i></b>     | 1 sheet of paper                         |
| <b><i>Position 2 :</i></b>     | 2 - 3 sheets of paper                    |
| <b><i>Position 3 :</i></b>     | 3 - 4 sheets of paper                    |
| <b><i>Position 4 :</i></b>     | 3 - 4 sheets of paper                    |
| <b><i>Position 5 or 6:</i></b> | Envelopes                                |
| <b><i>Position 6 :</i></b>     | Installing/removing the ribbon cartridge |

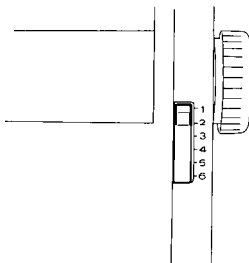

---

## Turning The Printer On

---

Plug the power cord into an AC power outlet and turn the printer on by pressing the power switch, located on the right side of the printer

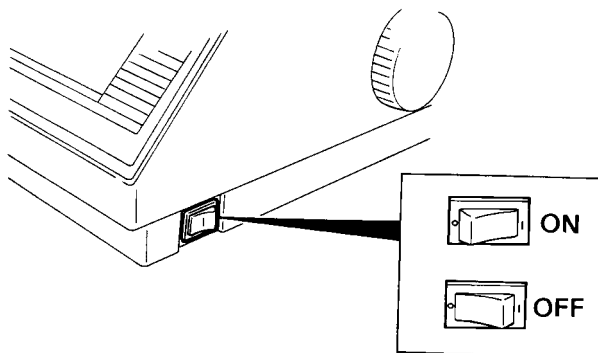

The ON/OFF status of the printer can be checked by the POWER indicator on the operation panel.

---

## Printing Your First Documents

---

### Self-Test Printing

The Self Test printout allows you to check the print quality and printer operations before connecting to the host computer. Proceed as follows:

1. Load the paper into the printer.
2. Turn the power switch ON while pressing and holding the PITCH key.

Only the following two function keys are enable during the test print:

- ◆ QUIET key (to switch the quiet mode ON/OFF)
- ◆ SELECT key (to start or stop the test print operation).

3. The Self Test format is composed by a Header followed by the Rolling ASCII print test.

Self-test printout:

ROM VER. 0.39 CG VER. 0.21

1 2 3 4 5 6 7 8 9 0 1 2 3 4 5 6 7 8 9 0 1 2 3

```

! " # $ % & ' ( ) * + , - . / 0 1 2 3 4 5 6
! " # $ % & ' ( ) * + , - . / 0 1 2 3 4 5 6 7
! " # $ % & ' ( ) * + , - . / 0 1 2 3 4 5 6 7 8
! " # $ % & ' ( ) * + , - . / 0 1 2 3 4 5 6 7 8 9
! " # $ % & ' ( ) * + , - . / 0 1 2 3 4 5 6 7 8 9 ;
! " # $ % & ' ( ) * + , - . / 0 1 2 3 4 5 6 7 8 9 ; <
! " # $ % & ' ( ) * + , - . / 0 1 2 3 4 5 6 7 8 9 ; < =
! " # $ % & ' ( ) * + , - . / 0 1 2 3 4 5 6 7 8 9 ; < = >
! " # $ % & ' ( ) * + , - . / 0 1 2 3 4 5 6 7 8 9 ; < = > ?
! " # $ % & ' ( ) * + , - . / 0 1 2 3 4 5 6 7 8 9 ; < = > ? @
! " # $ % & ' ( ) * + , - . / 0 1 2 3 4 5 6 7 8 9 ; < = > ? @ A
! " # $ % & ' ( ) * + , - . / 0 1 2 3 4 5 6 7 8 9 ; < = > ? @ A B
! " # $ % & ' ( ) * + , - . / 0 1 2 3 4 5 6 7 8 9 ; < = > ? @ A B C
! " # $ % & ' ( ) * + , - . / 0 1 2 3 4 5 6 7 8 9 ; < = > ? @ A B C D
! " # $ % & ' ( ) * + , - . / 0 1 2 3 4 5 6 7 8 9 ; < = > ? @ A B C D E
! " # $ % & ' ( ) * + , - . / 0 1 2 3 4 5 6 7 8 9 ; < = > ? @ A B C D E F
! " # $ % & ' ( ) * + , - . / 0 1 2 3 4 5 6 7 8 9 ; < = > ? @ A B C D E F G
! " # $ % & ' ( ) * + , - . / 0 1 2 3 4 5 6 7 8 9 ; < = > ? @ A B C D E F G H
! " # $ % & ' ( ) * + , - . / 0 1 2 3 4 5 6 7 8 9 ; < = > ? @ A B C D E F G H I
! " # $ % & ' ( ) * + , - . / 0 1 2 3 4 5 6 7 8 9 ; < = > ? @ A B C D E F G H I J
! " # $ % & ' ( ) * + , - . / 0 1 2 3 4 5 6 7 8 9 ; < = > ? @ A B C D E F G H I J K
! " # $ % & ' ( ) * + , - . / 0 1 2 3 4 5 6 7 8 9 ; < = > ? @ A B C D E F G H I J K L

```

## Carrier Movement Test

The Carrier test allows you to check the carrier movement. Proceed as follows:

1. Unload the paper from the printer
2. Turn the power switch ON while pressing and holding the PITCH key. The carrier starts to move from one end of the carrier shaft to the other end. The test continues until the power switch is turned OFF.

---

# Host Computer Connection

---

## Choosing The Connection

---

This printer can be connected to your host computer via two available interfaces:

- ◆ A 8-bit parallel interface
- ◆ A RS-232C serial interface (available as an option)

The interface connectors are located on the left front side of the printer

---

## Parallel Connection

---

Make sure that the printer and the host computer are turned OFF before connecting the interface cable.

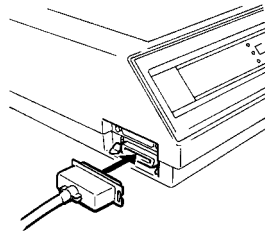

---

## Serial Connection

---

Make sure that the printer and the host computer are turned OFF before connecting the interface cable.

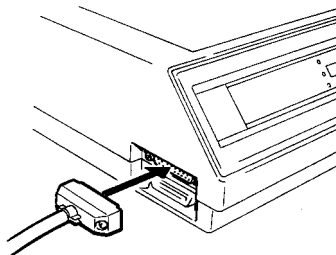

## Hexadecimal Printing

The Hex dump function allows you to print the data received from the host computer in the hexadecimal format. After connecting the printer to the host computer, you can print the hexadecimal dump of the data to verify the data received from the host computer. Proceed as follows:

1. Load the paper into the printer.
2. Turn the power switch ON while pressing and holding the LOAD/PARK key.
3. The Hex Dump print format is the following:

Address                      HEX data (16 bytes)                      ASCII characters

Hex dump printout:

```

                                1B 33
0680  1E 1B 70 00 21 40 23 24 25 5E 26 2A 28 29 31 32  . .p.!@##%^&*()12
0690  33 34 35 36 37 38 39 51 57 45 52 54 59 55 49 4F  3456789QWERTYUIO
06A0  50 41 53 44 46 47 48 4A 4B 4C 5A 5B 43 56 42 4E  PASDFGHJKLZXCVBN
06B0  4D 0A 21 40 23 24 25 5E 26 2A 28 29 31 32 33 34  M.!@##%^&*()1234
06C0  35 36 37 38 39 51 57 45 52 54 59 55 49 4F 50 41  56789QWERTYUIOPA
06D0  53 44 46 47 48 4A 4B 4C 5A 5B 43 56 42 4E 4D 0A  SDFGHJKLZXCVBNM.
06E0  21 40 23 24 25 5E 26 2A 28 29 31 32 33 34 35 36  !@##%^&*()123456
06F0  37 38 39 51 57 45 52 54 59 55 49 4F 50 41 53 44  789QWERTYUIOPASD
0700  46 47 48 4A 4B 4C 5A 5B 43 56 42 4E 4D 0A 21 40  FGHJKLZXCVBNM.!@
0710  23 24 25 5E 26 2A 28 29 31 32 33 34 35 36 37 38  ##%^&*()12345678
0720  39 51 57 45 52 54 59 55 49 4F 50 41 53 44 46 47  9QWERTYUIOPASDFG
0730  48 4A 4B 4C 5A 5B 43 56 42 4E 4D 0A 21 40 23 24  HJKLZXCVBNM.!@##
0740  25 5E 26 2A 28 29 31 32 33 34 35 36 37 38 39 51  %^&*()123456789Q
0750  57 45 52 54 59 55 49 4F 50 41 53 44 46 47 48 4A  WERTYUIOPASDFGHJ
0760  48 4C 5A 5B 43 56 42 4E 4D 0A 21 40 23 24 25 5E  KLZXCVBNM.!@##%^
0770  26 2A 28 29 31 32 33 34 35 36 37 38 39 51 57 45  &*()123456789QWE
0780  52 54 59 55 49 4F 50 41 53 44 46 47 48 4A 4B 4C  RTYUIOPASDFGHJKL
0790  5A 5B 43 56 42 4E 4D 0A 21 40 23 24 25 5E 26 2A  ZXCVBNM.!@##%^&*
07A0  28 29 31 32 33 34 35 36 37 38 39 51 57 45 52 54  ()123456789QWERT
07B0  59 55 49 4F 50 41 53 44 46 47 48 4A 4B 4C 5A 5B  YUIOPASDFGHJKLZX
07C0  43 56 42 4E 4D 0A 21 40 23 24 25 5E 26 2A 28 29  CVBNM.!@##%^&*()

```

4. Turn the power switch OFF to stop the hexadecimal printing. The printer returns to the normal printing.

# Operation

---

The operator panel on your printer enables you to access many of your printer's functions. This chapter introduces you to the operator panel, showing you how to use it, both in configuring your printer and in day-to-day usage. Additionally, you will learn how to load paper correctly for any of your daily printing needs.

<b>General Overview</b> .....	<b>3.2</b>
Display Messages .....	3.2
Indicators .....	3.4
Function Keys .....	3.6
Buzzer .....	3.9
<b>The Printer Setup</b> .....	<b>3.10</b>
Entering Printer Setup .....	3.10
Moving within the Printer Setup .....	3.10
Leaving the Printer Setup .....	3.11
Setup Listing Printing .....	3.22
<b>Paper Handling</b> .....	<b>3.23</b>
Paper Specifications .....	3.23
Setting The Friction Release Lever .....	3.24
Loading Single Sheets (Friction Feed Mode) .....	3.24
Inserting Fanfold Paper (Tractor Feed Mode) .....	3.25
Loading Envelopes (Friction Feed Mode) .....	3.32
Auto Paper Loading .....	3.33
Switching From Fanfold Paper to Single Sheet (Paper Park Function) .....	3.35
Tear Off Function .....	3.36

## General Overview

The operator panel enables you to perform many of the printer functions including pitch, font and printer setup selection. The operator panel is located in the front side of the printer and appears as follows:

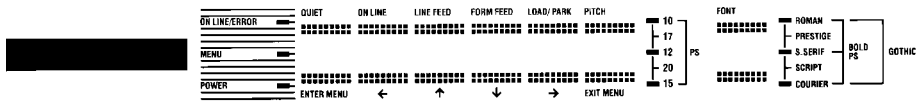

The operator panel consists of :

- ◆ **a 16- character display (Liquid Crystal Display)**  
shows various message usually regarding to the printing functions
- ◆ **nine indicators**  
report basic information about the printer's condition The indicators light up green
- ◆ **seven function keys**  
allow you to change the operating state of the printer

## Display Messages

The display messages can be divided into three main groups:

### STATUS MESSAGES:

Provide information about operating state of the printer.

### SETUP MESSAGES:

Display during the Printer Setup procedure.

### ERROR MESSAGES:

Signal any printer faults. See "Error Messages Description" in chapter 4.

---

The following list describes the printer status messages in alphabetical order:

EJECT ERR	This message is displayed when a paper eject error has occurred (ERROR indicator is blinking). If the VALID value is selected in the BUZZER function, the alarm sounds. To clear the error, press the FORM FEED/↓, LOAD-PARK/→ or ON LINE/← key to eject the paper.
CA POSITION ERR	This message is displayed when a carrier position error has occurred (ERROR indicator is blinking). If the VALID value is selected in the BUZZER function, the alarm sounds. To clear the error, press the ON LINE/← key to turn the printer on-line .
ON LINE USER *	This message is displayed when the printer is enabled to receive and to print data. The asterisk "*" indicates the user number selected in the Printer Setup(SELECT USER function).
OFF LINE USER *	This message is displayed when the printer is disabled to receive and to print data. The asterisk "*" indicates the user number selected in the Printer Setup (SELECT USER function).
PAPER EMPTY ERR	This message is displayed when a paper is not present in the printer (ERROR indicator is blinking). To clear the error, press the ON LINE/← key to turn the printer on-line
PAPER JAM	This message is displayed when a paper is jammed during the paper ejection (ERROR indicator is blinking).To clear the error, remove all jammed paper from the printer and load the paper properly.

## Indicators

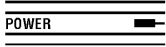

Lit when the printer power is ON.

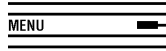

Lit when the printer is in the Setup mode.



Lit when the printer is in the on line status.  
Unlit when it is in the off line status.  
Blinks when an error has occurred.

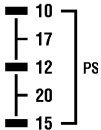

These indicators indicate the character pitch currently selected by the combination of them as shown below.

○ = off, \* = on

Pitch	Pitch Indicators
10 cpi	* ○ ○
12 cpi	○ * ○
15 cpi	○ ○ *
17 cpi	* * ○
20 cpi	○ * *
Proportional	* ○ *

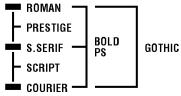

These indicators show the current font selected by the combination of them:

○ = off, \* = on

Font	Font Indicators
Draft	○ ○ ○
Roman	* ○ ○
Sans Serif	○ * ○
Courier	○ ○ *
Prestige	* * ○
Script	○ * *
Gothic	* ○ *
Bold	* * *

## Function Keys

---

The Function Keys can be activated in the Normal and in the Set Up modes

QUIET



### Normal Mode

When this key is pressed in the off-line status, the printer enters the Setup mode.



ENTER MENU

Pressing this key in the on-line status, alternates the Quiet mode ON/OFF.

Pressing this key together with the ON LINE/← key and the PITCH/EXIT MENU key, when the printer is off line clears the buffer except the download buffer and initializes the printer.

### Setup Mode:

Invalid.

---

ON LINE



### Normal Mode

Pressing this key alternates the on-line and off-line status.



Pressing this key together with the LINE FEED/↑ key:

- ◆ when the printer is offline, the paper is moved upwards by increments of 1/180 of inch.
- ◆ when the printer is online, it is possible to move up the position of the first printable line after an automatic loading.
- ◆ when the paper is at the tear off position and the printer is offline, moves the tear off position upwards by increments of 1/180 inch.

Pressing this key together with the FORM FEED/↓ key:

- ◆ when the printer is offline, the paper is moved downwards by increments of 1/180 of inch.
- ◆ when the printer is online, it is possible to move down the position of the first printable line after an automatic loading.

- ◆ when the paper is at the tear off position and the printer is offline, moves the tear off position downwards by increments of 1/180 inch.

Pressing this key together with the QUIET/ENTER MENU and the PITCH/EXIT MENU key, when the printer is offline clears the buffer except the download buffer and initializes the printer.

## Setup menu

When this key is pressed, the printer enters the Function Selection Mode.

---

LINE FEED



### Normal Mode



Pressing this key in the off-line status feeds the paper by one line. Holding this key feeds the paper by one line for the first three lines and then feeds the paper continuously from the fourth line.

Pressing this key together with the ON LINE/← key:

- ◆ when the printer is offline, the paper is moved upwards by increments of 1/180 of inch.
- ◆ when the printer is online, it is possible to move up the position of the first printable line after an automatic loading.
- ◆ when the paper is at the tear off position and the printer is offline, moves the tear off position upwards by increments of 1/180 inch.

## Setup Mode

Pressing this key scans forwards the functions of the values .

---

FORM FEED



### Normal Mode



Pressing this switch in the off-line status feeds the paper to the next top of form position when the tractor feed is selected.

Pressing this key together with the ON LINE/← key:

- ◆ when the printer is offline, the paper is moved downwards by increments of 1/180 of inch.
- ◆ when the printer is online, it is possible to move down the position of the first printable line after an automatic loading.
- ◆ when the paper is at the tear off position and the printer is offline, moves the tear off position downwards by increments of 1/189 inch.

### Setup Mode

Pressing this key scans backwards the functions or the values.

---

LOAD/PARK



### Normal Mode



Pressing this key loads the paper if the printer is in the paper empty condition. If the paper is loaded in the printer, pressing continuously this key, ejects the paper.

### Setup Mode

When this key is pressed, the printer enters the Value Selection Mode.

---

PITCH



### Normal Mode

Pressing this key in the off-line status selects the character pitch.



EXIT MENU

Pressing this key together with the QUIET/ENTER MENU and the ON LINE/← key, (when the printer is offline) clears the buffer except the download buffer and initializes the printer.

### Setup Mode

When this key is pressed, the printer exits the set up mode to the normal print mode.

FONT

**Normal Mode**

Pressing this key selects the font.

**Setup Mode**

Invalid

## ***Buzzer***

---

This printer is provided with a buzzer to indicate specific conditions. The buzzer signal changes according to the error detected. The buzzer only sounds when the BUZZER function is set to ON (see "The Printer Setup" described before). See the following table:

Sound	Cause
1 short "beep"	A BELL command is received
4 melody "beeps"	A paper empty error condition
Twice 2 short "beeps"	The friction release lever is moved while the paper is loaded in the printer
3 long "beeps"	The single sheets cannot be ejected
3 short "beeps"	The carrier cover is open

## *The Printer Setup*

The Printer Setup procedure allows you to set most of the printer's functions. You can perform this Printer Setup procedure via the operator panel. The keys scan and select the available functions and their values while the display shows the related messages.

### *Entering Printer Setup*

---

- ◆ Turn the printer on and the basic check is performed. You should see the following message:

**INITIAL CHECK OK**

- ◆ Do not press any function key and the display will show the following message automatically after a few seconds:

**ON LINE USER 1**

- ◆ Press the ON LINE/← key to switch the printer off line, the display will show:

**OFF LINE USER 1**

- ◆ Press the QUIET/ENTER MENU key to enter the Setup mode.

### *Moving within the Printer Setup*

---

#### *Function Selection Mode*

Press the ON LINE/← key to enter the Function Selection Mode (the displayed function blinks). Press the ↑ or ↓ keys to scan the functions forwards or backwards. When you wish to confirm the displayed function, press the LOAD-PARK/→ key, the displayed function will be selected (it stops blinking) and enter the Value Selection Mode.

#### *Value Selection Mode*

Press the LOAD-PARK/→ key to enter the Value Selection Mode (the displayed function value blinks). Press the ↑ or ↓ keys to scan forwards or backwards the values. When you wish to confirm the displayed value, press the ON LINE/← key, the displayed value will be selected (it stops blinking) and enter the Function Selection Mode

---

## *Leaving the Printer Setup*

---

When you wish to leave the current Printer Setup procedure, press the PITCH/EXIT MENU key, the new function/value settings will be stored and you exit the Setup mode. The display shows:

### **SETUP END**

The Setup procedure allows the selection of the following printer functions:

- ◆ Default Set Selection
- ◆ User Selection
- ◆ User Change Selection
- ◆ Emulation Types
- ◆ Form and Line Length
- ◆ Line Spacing
- ◆ Character Pitch
- ◆ Font Style
- ◆ Power On Condition
- ◆ Quiet Mode
- ◆ Paper Autoloading
- ◆ Print Direction
- ◆ Buffer Overflow
- ◆ CR and LF Code
- ◆ Cancel Code
- ◆ Paper Empty Sensor
- ◆ Skip-over perforation
- ◆ Slashed Character
- ◆ Print Buffer Selection
- ◆ ASF Selections
- ◆ Ribbon Selection
- ◆ Auto Tear-Off function
- ◆ Fanfold Paper Initialization
- ◆ Buzzer
- ◆ Character Sets
- ◆ Graphics Mode
- ◆ Interfaces Selection
- ◆ SELECTIN Signal (\*)

- ◆ AUTOFEED XT (\*)
- ◆ Serial Protocol (\*\*)
- ◆ Baud Rate (\*\*)
- ◆ Data Bits (\*\*)
- ◆ Parity Bit (\*\*)
- ◆ Stop Bits (\*\*)
- ◆ CTS Control (\*\*)

(\*) If Parallel interface is selected

(\*\*) If Serial interface is selected

The factory default settings are:

No	Function	Default value			
01	DF.SET	OFF			
02	SELUSER	1			
03	CHG USER	1			
		User 1	User 2	User 3	
04	EMUL	IBM	EPSON	EPSON	
05	PAGE-L	11"	11"	11"	
06	LPI	6	6	6	
07	MARGIN	160	160	160	
08	CPI	10	10	10	
09	FONT	DFAFT	DRAFT	DRAFT	
10	PW ON	ONLINE	ONLINE	ONLINE	
11	QUIET	OFF	OFF	OFF	
12	LOAD	OFFLINE	OFFLINE	OFFLINE	
13	DIRECT.	BI(C)	BI (C)	BI (C)	
14	BUF FUL	LF	LF	LF	
15	CR CODE	CR	CR	CR	
16	LF CODE	LF	LF+CR	LF+CR	
17	CAN	VALID	VALID	VALID	
18	PE DETECT	ON	ON	ON	
19	SKIP	INVALID	INVALID	INVALID	
20	ZERO	0	0		
21	BUFFER	PRINT	PRINT	PRINT	
22	ASF	INVALID	INVALID	INVALID	
23	RIBBON	BLACK	BLACK	BLACK	

24	TEAR OFF	OFF	OFF	OFF
25	TEAR OFF	1	1	
26	PAPER INT	OFF	OFF	OFF
27	BUZZER	ON	ON	ON
28	CHR SET	SET1	SET1	SET1
29	CODE PAGE	437	437	
30	IBM AGM	OFF	OFF	OFF
31	CHR TBL	ITAL	ITAL	ITAL
32	CHR SET	USA	USA	USA
50	I/F	PARALLEL	PARALLEL	PARALLEL
51	SLCT IN	INVAL	INVAL	INVAL
52	AUTO XT	INVAL	INVAL	INVAL
53	PROT	R/B	R/B	R/B
54	BAUD	9600BPS	9600BPS	9600BPS
55	DATA BITS	8	8	8
56	PARITY	NONE	NONE	NONE
57	STOP BIT	1	1	1
58	CTS	INVALID	INVALID	INVALID

This printer can store the data functions in each User setting as different data.

The available functions of the Setup procedure are:

---

### Function 01 DEFAULT SET

Selects the field to be reset to the factory set values,

- 01 OFF
- 02 USER 1
- 03 USER 2
- 04 USER 3
- 05 ALL

---

### Function 02 SELECT USER

Specifies what user setting to use among USER 1, USER 2 or USER 3 when turning on the printer.

- 01 1 User 1
- 02 2 User 2
- 03 3 User 3

---

**Function 03 CHANGE USER**

Specifies which user setting to change.

- 01 1 User 1
  - 02 2 User 2
  - 03 3 User 3
- 

**Function 04 EMULATION**

Selects IBM or EPSON emulation.

- 01 IBM (IBM Proprinter XL24/XL24E/XL24 AGM)
  - 02 EPSON (EPSON LQ-850/1050)
- 

**Function 05 FORM LENGTH**

Selects the default form length.(in inches)

- 01 3 "
- 02 3.5 "
- 03 4 "
- 04 5 "
- 05 5.5 "
- 06 6 "
- 07 7 "
- 08 8 "
- 09 8 1/3 "
- 10 8.5 "
- 11 9 "
- 12 11 "
- 13 11 2/3 "
- 14 12 "
- 15 14 "
- 16 15 "

---

**Function 06 LINE SPACING**

Selects the default line spacing( in inches).

01 6 (1/6 Inches)

02 8 (1/8 Inches)

---

**Function 07 LINE LENGTH**

Selects the default print margin(in characters)

01 20

02 40

03 80

04 110

05 115

06 136

---

**Function 08 CHARACTER PITCH**

Selects the default character pitch. (in cpi)

01 10

02 12

03 15

04 17.1

05 Proportional

---

**Function 09 FONT STYLE**

Selects the default font.

01 DRAFT

02 ROMAN

03 SANS SERIF

04 COURIER

05 PRESTIGE

06 SCRIPT

07 GOTHIC

08 BOLD PS

---

**Function 10 POWER ON**

Sets the power-on condition to the on-line or off-line status.

01 ON LINE

02 OFF LINE

---

---

**Function 11 QUIET MODE**

Sets the power-on condition to the quiet mode or not.

- 01 OFF
  - 02 ON
- 

**Function 12 AFTER AUTOLOADING**

Selects the printer condition to the on-line or off-line status after autoloading the paper by the LOAD-PARK/→ key.

- 01 ONLINE
  - 02 OFFLINE
- 

**Function 13 PRINT DIRECTION**

- 01 BI (A)

Bi-Direction (All)

character printing = bi-direction

graphics printing = bi-direction

- 02 BI (C)

Bi-Direction (Cha)

character printing = bi-direction

graphics printing = uni-direction

- 03 UNI

Uni-Direction

character printing = uni-direction

graphics printing = uni-direction

---

**Function 14 BUFFER FULL**

Determines if a line feed will be added at the end of an over-full line.

- 01 LF
  - 02 NO LF
- 

**Function 15 CR CODE**

Adds a line feed code to every carriage return code.

- 01 CR+LF
- 02 CR

---

**Function 16 LF CODE**

Adds a carriage return code to every line feed code.

- 01 LF+CR
  - 02 LF
- 

**Function 17 CANCEL CODE**

Sets the function of the CAN (cancel) code.

- 01 VALID  
(the printer will cancel all the information in the input buffer when the CAN code is received).
  - 02 INVALID  
(the CAN code is ignored).
- 

**Function 18 PAPER EMPTY SENSOR**

Sets the paper empty sensor. When the paper empty sensor is OFF, you will not be warned that the printer is out of paper.

- 01 ON
  - 02 OFF
- 

**Function 19 SKIP PERFORATION**

Selects the skip-over-perforation.( in inches)

- 01 0.5 "
  - 02 1 "
  - 03 INVALID
- 

**Function 20 ZERO CHARACTER**

Selects a slashed or unslashed zero character.

- 01 0  
(not slashed)
- 02 0 + /  
(slashed)

---

**Function 21 SELECTION OF RAM**

Selects the capacity of the input buffer. (Selects the download command enable/disable.)

- 01 PRINT  
(print buffer)
  - 02 D. LOAD  
(downloaded buffer)
- 

**Function 22 ASF**

Selects the ASF installed or not installed.

- 01 INVALID  
(not installed)
  - 02 VALID  
(installed)
- 

**Function 23 RIBBON MODE**

Selects the black ribbon.

- 01 BLACK
- 

**Function 24 AUTO TEAR OFF**

Selects the timing for the auto tear-off function (in seconds).

- 01 OFF
  - 02 ON1  
(1 sec)
  - 03 ON3  
(3 sec)
  - 04 ON15  
15 sec
- 

**Function 25 TEAR OFF POSITION**

Specifies a tear off condition.

- 01 1  
(when the paper is placed at the TOF position, a tear-off is carried out)
  - 02 2  
(any Position, regardless of paper position, a tear-off is always carried out)
-

---

**Function 26 PAPER INITIALIZATION**

Selects fanfold paper initialization. If the paper has already been loaded when the power is turned ON. The printer will park and then auto-loads the paper to the initial printing position, this function is only valid in Push Tractor Mode.

- 01 OFF
- 02 ON

---

**Function 27 BUZZER**

Enables or disables the printer's buzzer.

- 01 ON
- 02 OFF

---

**Function 28 IBM CHARACTER SET**

This selects a character set in the IBM mode.

- 01 SET1  
(Character Set 1)
- 02 SET2  
(Character Set 2)

---

**Function 29 CODE PAGE**

Selects a code page in the IBM or EPSON mode. In EPSON mode, the Code Page is valid if the GRA.1 is selected in the CHARACTER TABLE function.

- 01 437  
(USA)
- 02 850  
(MULTILINGUAL)
- 03 860  
(PORTUGAL)
- 04 863  
(FRENCH-CANADIAN)
- 05 865  
(NORDIC)

---

**Function 30 IBM AGM MODE**

Specifies the graphics mode in the IBM mode.

- 01 ON
- 02 OFF

---

### Function 31 CHARACTER TABLE

Specifies the 80H-FFH character table used in the EPSON mode.

- 01 ITAL  
Italic
  - 02 GRA.1  
Graphic 1 (Code Page function enable)
  - 03 GRA.2  
Graphic 2 (Code Page function disable)
- 

### Function 32 INTERNATIONAL CHARACTER TABLE

Selects a special foreign character set in the EPSON mode.

- 01 USA  
English
- 02 FR  
France
- 03 GE  
Germany
- 04 UK  
English
- 05 DN  
Danish 1
- 06 SW  
Swedish
- 07 IT  
Italian
- 08 SP  
Spanish 1
- 09 JA  
Japanese
- 10 NOR  
Norwegian
- 11 DN2  
Danish 2
- 12 SP2  
Spanish 2
- 13 L-AME  
Latin American

---

**Function 50 INTERFACE**

Selects the parallel or serial interface.

- 01 PARALLEL
  - 02 SERIAL
- 

**Function 51 SELECT-IN SIGNAL**

Enables the function of the SELECT IN pin in the parallel interface. (EPSON mode only).

- 01 VALID
  - 02 INVALID
- 

**Function 52 AUTOFEED-XT SIGNAL**

Enables the function of the AUTOFEED XT pin in the parallel interface. (EPSON mode only).

- 01 VALID
  - 02 INVALID
- 

**Function 53 PROTOCOL**

Selects the serial protocol.

- 01 R/B  
(READY/BUSY)
  - 02 XON/XOFF
- 

**Function 54 BAUD RATE**

Selects the data transfer rate for the serial interface (in bits per second).

- 01 300BPS
  - 02 600BPS
  - 03 1200BPS
  - 04 2400BPS
  - 05 4800BPS
  - 06 9600BPS
- 

**Function 55 BIT LENGTH**

Selects the number of data bits for the serial interface

- 01 8
- 02 7

---

### Function 56 PARITY BIT

Selects the parity for the serial interface.

- 01 NONE
  - 02 ODD
  - 03 EVEN
  - 04 IGNORE
- 

### Function 57 STOP BIT LENGTH

Selects the number of stop bits for the serial interface

- 01 1
  - 02 2
- 

### Function 58 CTS

Overrides CTS (clear to send) control on the serial interface.

- 01 INVALID
  - 02 VALID
- 

When you wish to leave the current Printer Setup procedure, press the PITCH/EXIT MENU key, the new function/value settings will be stored and you exit the Setup mode. The display show:

**SETUP END**

---

## *Setup Listing Printing*

---

If you can verify the current printer settings on the Setup listing, proceed as follows:

- ◆ Turn the printer Off and then On.
- ◆ Check that the paper is present in the printer and then, press the QUIET/ENTER MENU key about 5. sec. (FUNCTION & MENU message will be displayed).
- ◆ The printer prints the current listing and then returns to the Normal print mode.

# Paper Handling

## Paper Specifications

Use the correct paper in your printer. This is an essential starting point for obtaining good results in your printout.

<i>Fanfold Paper</i>				
Width			101-406 mm (4 - 16 inches)	
Weight	Single		60 - 80 g/m <sup>2</sup>	
	Multipart	One-time carbon sheet	50 g/m <sup>2</sup>	1 + 2 copies
			50 - 60 g/m <sup>2</sup>	1 + 1 copies
	Chemical Carbon		34 - 50 g/m <sup>2</sup>	1 + 3 copies
			40 - 50 g/m <sup>2</sup>	1 + 2 copies
			50 - 60 g/m <sup>2</sup>	1 + 1 copies
Carbon backed paper		40 - 50 g/m <sup>2</sup>	1 + 2 copies	
		50 - 60 g/m <sup>2</sup>	1 + 1 copies	
Number of Copies			1 original plus 3 copies	
Total Thickness			Max.0.28 mm	

<i>Single Sheets</i>	
Width	101 - 420 mm (4 - 16.5 inches)
Length	127 - 304 mm (5 - 12 inches )
Weight	60 - 90 g/m <sup>2</sup>

## ***Setting The Friction Release Lever***

---

The friction release lever is located at the left rear side of the printer, its functions are as follows:

◆ ***Friction position***

Select this position when using the single sheets (Friction Feed Mode) or the Auto Sheet Feeder (ASF).

◆ ***Tractor position***

Select this position when using the fanfold paper (Tractor Feed Mode: Push tractor, Pull tractor (rear and bottom path)).

## ***Loading Single Sheets (Friction Feed Mode)***

---

Single sheets are inserted from the top of the printer (Top insertion). You can load single sheets whether fanfold paper is inserted or not. If no fanfold paper is present, proceed as follows:(otherwise, see "Switching From Fanfold Paper to Single Sheet", in this chapter).

1. Set the friction release lever to the friction position.

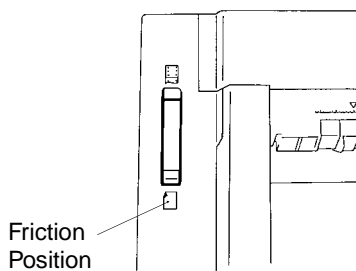



---

***Make sure that the paper stand is installed on the printer.***

---

2. Adjust the sheet guide according to the left margin that you desire.

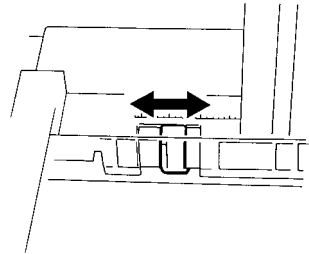

3. Load the paper into the printer by aligning the left edge of the paper to the sheet guide. Press the LOAD-PARK/→ key to feed the paper

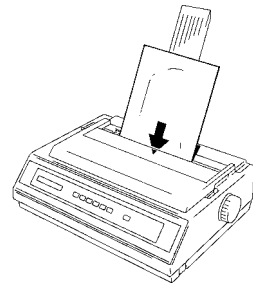

## ***Inserting Fanfold Paper (Tractor Feed Mode)***

---

The use of the tractor unit is recommended when printing on fanfold paper. This printer offers two tractor unit positions (two paper feeding modes); "push tractor position" and "pull tractor position". In pull tractor position, the paper can be loaded from the rear or the bottom of the printer.

*Paper Paths*

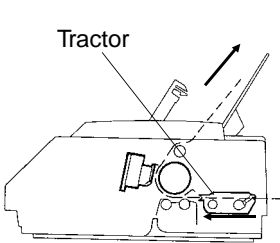

Push Tractor

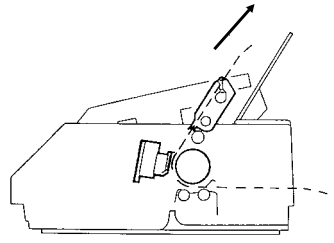

Pull Tractor (Rear Path)

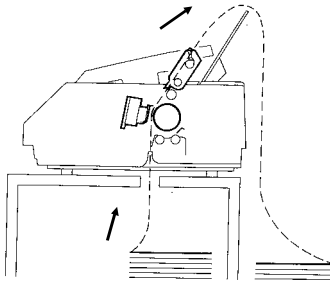

Pull Tractor (Bottom Path)

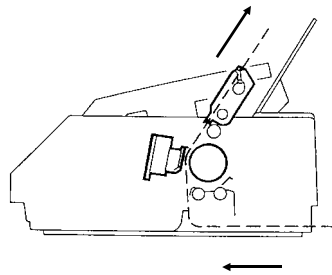

Pull Tractor (Bottom Path (Rear))

## Push Tractor Position

In Push tractor position, the paper is *pushed* by the tractor from the rear of the printer.





---

**When printing in the pull tractor position, use the paper stand**

---

1. Set the friction release lever to the tractor position

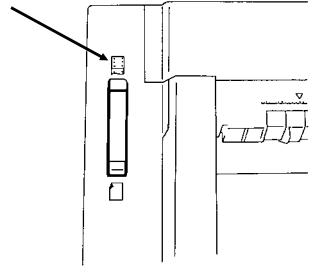
Tractor position



2. Move the tractor set lever of the left tractor forward to unlock the tractor. Move the left tractor so that the printing starts from your desired print start position. Move the tractor set lever of the left tractor rearward to lock the tractor. Move the tractor set lever of the right tractor forward to unlock the tractor.

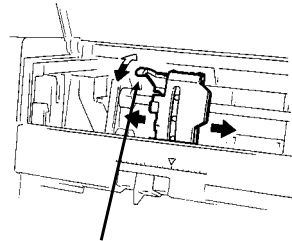

Tractor set lever

3. Open the left and right tractor covers. Insert the paper under the rear cover. Load the paper and align the paper holes with the tractor pins of the left and the right tractor, respectively.

Tractors

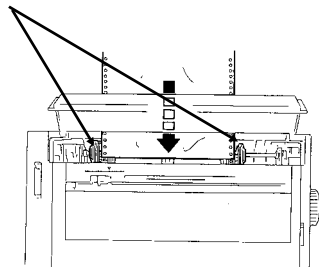



***Make sure that the paper is correctly aligned with the left and right tractors.***

4. Close the left and right tractor covers. Slide the right tractor to take up any slack in the paper. Move the tractor set lever of the right tractor to lock the tractor.

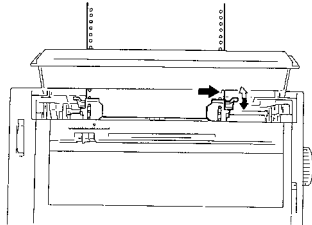

5. Rotate the platen knob to feed the paper forward slightly as shown below.

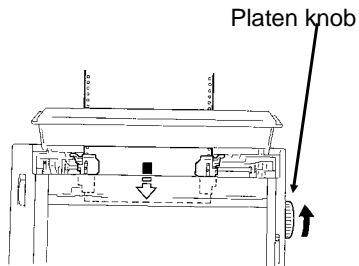

When loading *chemical multicopy fanfold paper* in push tractor you should install the fanfold paper guide

Proceed as follows:

1. Find the fanfold paper guide

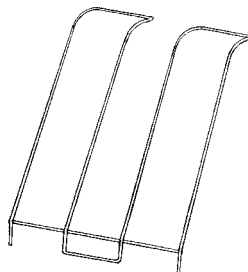

2. Position the fanfold paper guide on the paper stand.

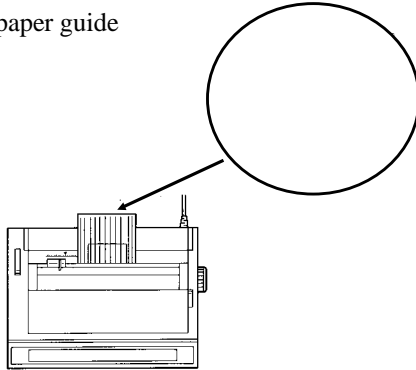

**Remove the fanfold paper guide when loading single sheets.**

### ***Pull Tractor Position***

In the Pull tractor position, the paper is *pulled* by the tractor from the rear or the bottom of the printer.

### ***Loading Paper From The Rear Paper Path***

1. Move the tractor set lever of the left tractor forward to unlock the tractor.  
Move the left tractor so that the printing starts from your desired print start position.  
Move the tractor set lever of the left tractor rearward to lock the tractor.  
Move the tractor set lever of the right tractor forward to unlock the tractor.

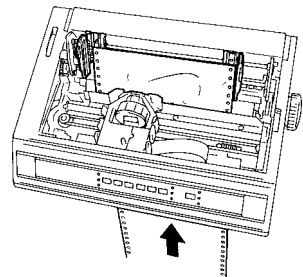

2. Move the right tractor to adjust the tractor to the paper width. Open the left and right tractor covers. Move the gap set lever to position 6. Insert the paper under the rear cover. Load the paper and align the paper holes with the tractor pins of the left and the right tractor, respectively.

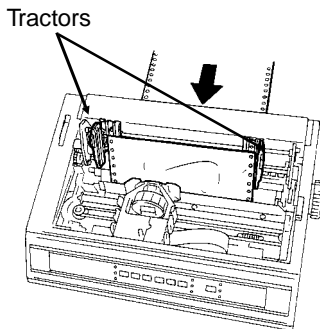



---

***Make sure that the paper is correctly aligned with the left and right tractors.***

---

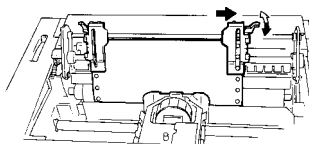
3. Close the left and right tractor covers. Slide the right tractor to take up any slack in the paper. Move the tractor set lever of the right tractor to lock the tractor.



4. Move the gap set lever to the proper position to set the paper thickness.

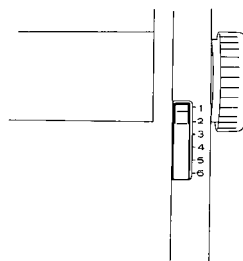

## Loading Paper From The Bottom Paper Path

1. Move the tractor set lever of the left tractor forward to unlock the tractor. Move the left tractor so that the printing starts from your desired print start position. Move the tractor set lever of the left tractor rearward to lock the tractor. Move the tractor set lever of the right tractor forward to unlock the tractor.

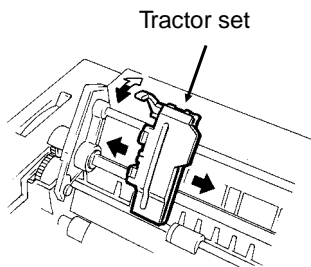

2. Move the right tractor to adjust the paper width. Open the left and right tractor covers. Move the gap set lever to position 6. Insert the paper into the printer from the slot at the bottom of the printer. Load the paper and align the paper holes with the tractor pins of the left and the right tractor, respectively.

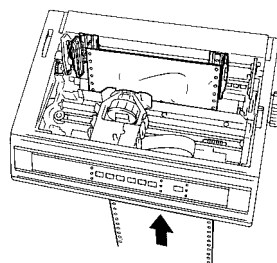

***Make sure that the paper is correctly aligned with the left and right tractors.***

3. Close the left and right tractor covers. Slide the right tractor to take up any slack in the paper. Move the tractor set lever of the right tractor to lock the tractor. Move the gap set lever to the proper position to set the paper thickness.

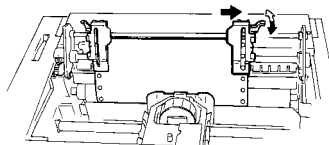

Before loading the crimped form (If the crimped form is not correctly loaded, a paper jam may occur), check the correct direction of the form

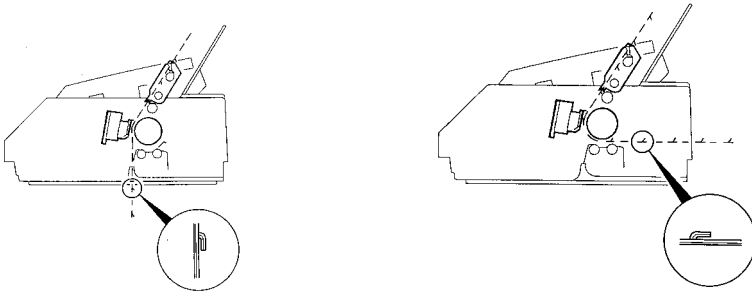

## Loading Envelopes (Friction Feed Mode)

The envelopes must be only inserted from the top of the printer (Top insertion).

Select the suitable gap set lever position according to the thickness of the envelope to be loaded (i.e., if the thickness of the envelope is 0.35 mm (0.014 inches), set the gap set lever to Position 5 or 6.). To load the envelopes, proceed as follows:

1. Move the friction release lever to the Tractor position. Make sure that the paper stand is installed on the printer.

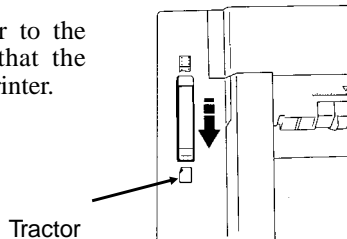

2. Insert the envelope, aligning the left edge of the paper to the sheet guide. Move the friction release lever to the Friction position.

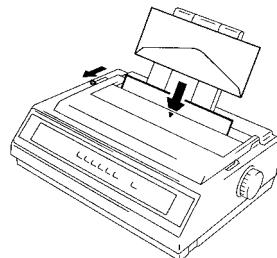



---

***When moving the friction release lever at the same time put your fingers on the top edge of the envelope to prevent it from being moved.***

---

After doing that, if the envelope is pulled out from the printer, do step 2 again.

Press the LOAD-PARK/→ key to feed the envelope to its print start position and then, press the ON LINE/← key to make the printer ready for printing.

## ***Auto Paper Loading***

---

This printer has an Auto Paper Loading function that automatically feeds the paper to the top of form position.



---

***The Auto Paper Loading function can be only available in Push tractor mode.***

---

### ***Single Sheet***

The Single Sheet can be loaded into the printer automatically when the FORM FEED/↓ or LOAD-PARK/→ key is pressed and the following conditions are performed:

- ◆ Printer in Off-line status.
- ◆ Paper empty condition.
- ◆ The friction release lever is set at the Friction position.



---

***If the Auto Paper Loading fails, a paper jam error (the ERROR indicator blinks) or a paper empty error will occur (the ERROR indicator blinks and the buzzer sounds). Make sure that all four above conditions have been performed and then try to load the paper again.***

---

### *Single Sheet (ASF)*

The Single Sheet can be loaded from the ASF automatically when the LINE FEED/↑, the LOAD-PARK/→ or the FORM FEED/↓ TOF key is pressed and the following conditions are performed:

- ◆ Printer in Off-line status.
- ◆ Paper empty condition.
- ◆ The friction release lever is set at the Friction position.
- ◆ Printer in Auto Sheet Feeder mode.

When the Auto Paper Loading function is performed, the printer first tries to load the single sheet from the manual insertion slot if the printer does not detect paper, the printer automatically performed the Auto Paper Loading from the ASF.

### *Fanfold Paper (Push tractor)*

The fanfold paper can be loaded into the printer automatically when the FORM FEED/↓ or the LOAD-PARK/→ key is pressed and the following conditions are performed:

- ◆ Printer in Off-line status.
- ◆ Paper empty condition.
- ◆ The friction release lever is set at the Tractor position.



---

***If the Auto Paper Loading fails, a paper jam error (the ERROR indicator blinks) or a paper empty error will occur (the ERROR indicator blinks and the buzzer sounds). Make sure that all three above conditions have been performed and then try to load the paper again.***

---

### *Auto Loading Position Adjustment Mode*

In the Auto Paper Loading mode, the paper load position is set at the factory default position. However, you can adjust the position by following the procedure:

1. Press the LOAD-PARK/→ key to perform the Auto Paper Loading.

Adjust the Auto Paper Loading position by pressing the ON LINE/← key together with the LINE FEED/↑ key or the ON LINE/← key together with the FORM FEED/↓ key (during the adjustment, the ON LINE/ERROR and MENU indicators are blinking.)

2. The adjustable range is 1/6" to +1" from the factory default position. If the adjusted position is out of this range, the setting will be ignored (the buzzer sounds.)
3. Press the ON LINE/← key to save the new Auto Loading position.
4. To cancel the Auto Loading Position Adjustment Mode, press the FORM FEED/ ↓ key.

## ***Switching From Fanfold Paper to Single Sheet (Paper Park Function)***

---

If you have been using fanfold paper in the Push tractor position and you want to load single sheets do not remove the fanfold paper but park it.

Make sure that the printer is in Off line status. You can perform the paper switching as follows:

1. Tear the printed fanfold paper along the last perforation.
2. Press the LOAD-PARK/→ key. The fanfold paper will be parked.
3. Set the friction release lever to the Friction position.
4. Insert a single sheet into the printer.
5. Press the FORM FEED/ ↓ or the LOAD-PARK/ → key. The single sheet is loaded automatically.
6. After printing on the single sheet, set the friction release lever to the Tractor position to resume printing on the fanfold paper.

## ***Tear Off Function***

---

This function allows to feed the fanfold paper to the tear-off position. This function is valid when the printer is in Push tractor mode and the AUTO TEAR OFF function is set to ON (1 SEC), ON(3 SEC) or ON (15 SEC) in the Printer Setup.

### ***Tear-off operation***

The tear-off function is valid both in the on-line and off-line status.

- ◆ When the TEAR OFF POSITION function is set to the 1 value :

The printer feeds the paper to the tear-off position whenever the paper is at the TOF position (and no further data is received or the printer is in off-line status) and no key is pressed for a certain period (that it is selected by the AUTO TEAR OFF function.)

- ◆ When the TEAR OFF POSITION function is set to the 2 value :

The printer feeds the paper so that the last printed line will be fed to the carriage cover position, when no further data is received and no key is pressed for a certain period (that it is selected by the AUTO TEAR OFF function.). The paper is fed regardless of the position where the paper is placed.



---

***When the paper is at the tear-off position, the ON LINE/ERROR and MENU indicators are blinking.***

---

#### ***When the paper is torn off in the on-line status :***

The printer automatically returns the paper (tear off down) to its original position when the data is received. If the TEAR OFF POSITION function is set to the 2 value the printer starts to return the paper approximately 5 seconds after the paper is fed.

#### ***When the paper is torn off in the off-line status :***

The printer returns the paper (tear off down) to its original position when the QUIET/ENTER MENU and ON LINE/← keys or the LINE FEED/↑,FORM FEED/↓, LOAD-PARK/ → are pressed.

## *Tear-off position adjustment*

The tear-off position can be adjusted by following the procedure below:

- ◆ Select the 1 value in the TEAR OFF POSITION function in the Printer Setup.
- ◆ Set the printer in off-line status.
- ◆ Perform the tear-off operation.
- ◆ Adjust the tear-off position by pressing both the ON LINE/← and the LINE FEED/↑,keys or the ON LINE/← and the.FORM FEED/↓.keys
- ◆ The paper is fed while the above keys are pressed. When tear-off down is executed, automatically the new tear-off position is set and the buzzer sounds to indicate that the setting is complete.

If the buzzer sounds while the keys are held, the printer stops feeding the paper and alerts that you have exceeded the adjustable range.



---

# Maintenance

---

This chapter contains information about printer maintenance, including cleaning operations and problem solving tips.

<b><i>Cleaning The Printer</i></b> .....	<b>4.2</b>
Replacing The Ribbon Cartridge .....	4.2
<b><i>Error Handling</i></b> .....	<b>4.4</b>
Error Message Description .....	4.4

## Cleaning The Printer



---

***Make sure the printer has been turned off for at least 15 minutes before starting any cleaning operations.***

---

Periodic cleaning will help keep your printer in top condition so that it will always provide optimal performance.

- ◆ Use a neutral detergent or water solution on a soft cloth to clean dirt and grease from the cabinet of the printer.
- ◆ Do not use an abrasive cloth, alcohol, paint thinner or similar agents because they may cause discoloration and scratching.
- ◆ Be especially careful not to damage the electronic and mechanical components.

## Replacing The Ribbon Cartridge

Make sure that the printer is turned OFF.



---

***The print head becomes extremely hot during operation. Turn the printer off and wait approximately 15 minutes before moving the carriage.***

---

1. Remove the carriage cover, then manually move the carriage to the center of the printer.

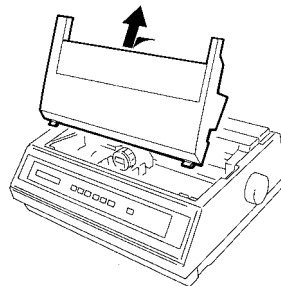

2. Set the gap set lever to its rearmost position 6 to provide the maximum distance between the print head and the platen for smooth removal.

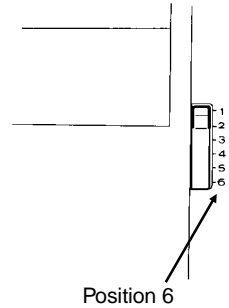

3. Remove the ribbon cartridge by pressing the two plastic clips on both sides inward of the ribbon cartridge. Return the carriage cover on the printer.

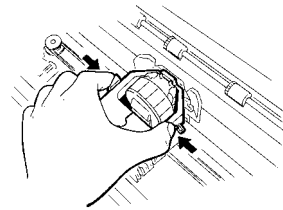

## Error Handling

When an error condition exists: the ERROR indicator blinks, the buzzer sounds if the BUZZER function is set to ON in the Printer Setup mode and the display will show the error message.

### Error Message Description

---

#### PAPER EMPTY ERR

Indication: Printer runs out of paper.

Solution: Load paper into the printer and press the ON LINE/ ← key to make the printer on-line.



---

***This error is only indicated when the PE DETECT function, is set to ON in the Printer Setup mode.***

---

#### CA POSITION ERR

Indication: A carriage position error has occurred.

Solution: Press the ON LINE/ ← key to make the printer on-line.

#### HP ERR (at Power On)

Indication: A home position error has occurred.

Solution: Try to turn the power switch OFF and then ON again. If the error is not cleared, call Technical Assistance.

#### ASF ERR

Indication: A paper load or eject error has occurred in the ASF mode.

Solution: To clear the error at the printing, press the ON LINE/ ← key to make the printer on-line and resume printing.



---

***To clear the error at loading or ejecting the paper, press the FORM FEED/↓ or LOAD/PARK/→ key to load or eject the paper.***

---

#### EJECT ERR (Single sheet)

Indication: A paper eject error has occurred,

Solution: Press the FORM FEED/↓, LOAD-PARK/→, ON LINE/ ← key to eject the paper.

**PULL UNIT ERR**

Indication: A pull tractor error has occurred during the printing in the pull tractor unit.

Solution: Install the tractor unit properly and press the ON LINE/ ← key to make the printer on-line.

**PAPER LEVER ERR**

Indication: The friction release lever has been moved while the printer was powered on and the paper was loaded.

Solution: Return the friction release lever to its original position and press the ON LINE/ ← key to make the printer on-line.

**PAPER JAM ERR**

Indication: A paper jam error has occurred.

Solution: Remove the paper jam from the printer and load the paper into the printer properly.



---

# ***Options***

---

This chapter describes the installation of the available printer option: the Automatic Sheet Feeder (ASF).

<b><i>Automatic Sheet Feeder</i></b> .....	<b>5.2</b>
Description .....	5.2
Unpacking .....	5.2
Installation .....	5.3
Paper Specifications.....	5.5
Paper Loading.....	5.5
ASF Removal.....	5.8

## ***Automatic Sheet Feeder (ASF)***

### ***Description***

---

This Automatic Sheet Feeder (ASF) provides fast and automatic single sheet feeding. This option is quickly and easily installed onto the printer by the operator. No tools or special equipment are necessary. Operation of the sheet feeder is relatively simple and with proper installation and care, it will provide long and trouble-free service. The single sheets are contained into an adjustable paper feed bin and are fed by the feeder .

### ***Unpacking***

---

Open the box that contains the Automatic Sheet Feeder (ASF).

Check that everything is present and with no shipping damage.

Notify any damage to your supplier.

1. Take out the accessories from the box.
2. Identify the ASF accessories.

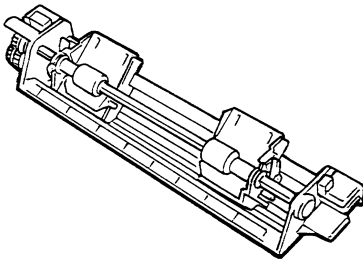

ASF Unit

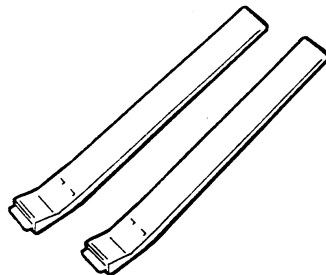

Single Sheet Stand

## Installation

---

Make sure that the printer is turned OFF and the paper is not present

Select the ASF mode via the operator panel: select the VALID value in the ASF function (see "The Printer Setup" in Chapter 3).

1. Remove the rear cover.

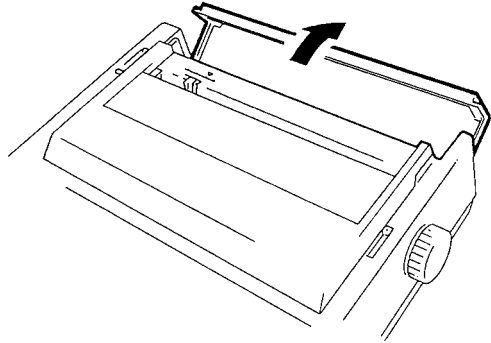

2. From the rear of the printer, insert the tabs on both sides of the ASF into the grooves of the side frame. Push the ASF in the direction indicated by the arrow.

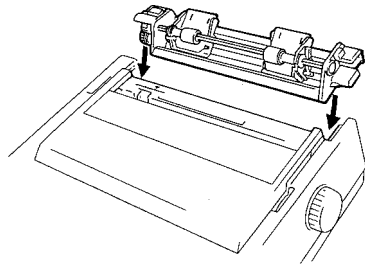

3. Ensure that both tabs of the ASF Unit are securely caught by the side frame.

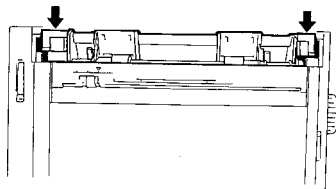

4. Move the friction release lever to the Friction position.

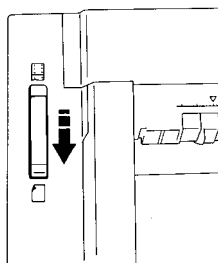

5. Install the two single sheet stands anywhere between the left and right paper guides.

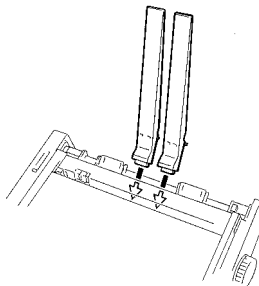

## ***Paper Specifications***

---

The following paper specifications should be adhered to in order to assure reliable feeder operation. Paper not conforming to these specifications may be used in the ASF, however, the results cannot be guaranteed. A brief test of out-of-specification paper should be conducted prior to regular use.

Most paper is sensitive to extreme temperature and humidity conditions, the paper performance in the ASF and printer may be adversely affected by these conditions:

<b><i>Number of bin</i></b>	1
<b><i>Bin Capacity</i></b>	Up to 20 sheets
<b><i>Paper Format</i></b>	A4, Letter and Legal
<b><i>Paper Size</i></b>	
Length	min. 139.7 (5.5 inches) max. 356 mm (14 inches)
Width	min. 139.7 mm (5.5 inches) max. 356 mm (14 inches)
Weight	from 60 to 90 g/m <sup>2</sup>
<b><i>Temperature and Humidity</i></b>	
Operating	16 to 24 ° C, 40 to 60% (non condensing)
Storage	20 to 55 ° C, 15 to 80% (non condensing)



---

***Plain bond, typewriter quality paper should be used for optimum performance. Paper must be well cut and in pristine condition without creases, surface or edge damages. It must be flat without being curled or curved. Not multi-part forms can be used.***

---

## Paper Loading

---

Make sure that all preliminary operations described before have been executed, then follow the sequence:

1. Push the left and right paper guides downward all the way until they stop

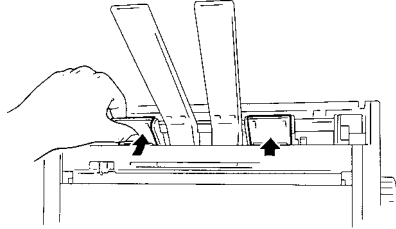

2. Move the left paper guides so that the printing starts from your desired print start position.

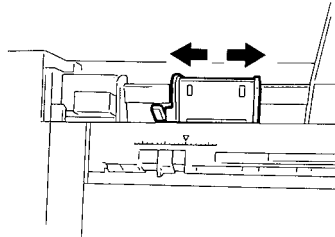

---

*Fan the paper stack before placing it on the ASF*

---

3. Load the paper, aligning the left edge of the paper to the left hopper. Move the right paper guide until it aligns with the right edge of the paper.

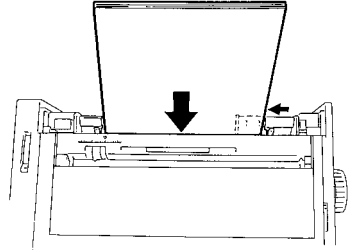

---

***Make sure that the paper is placed straight in the ASF.***

---

4. Move the left and right levers forward.

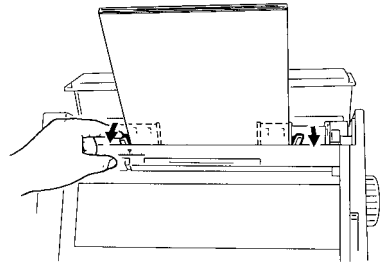

5. Install the paper stand on the printer.

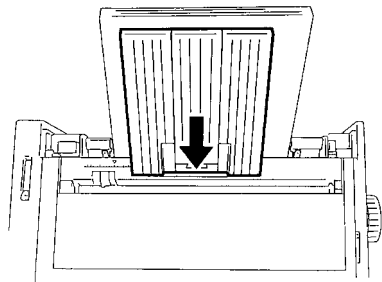



---

***Do not add paper into the ASF when some sheets remain loaded. If you wish to load additional paper, first remove all paper from the ASF, then load again paper correctly.***

---

## ***ASF Removal***

---

If you want to remove the ASF from the printer, press both ends of the ASF in the direction of the arrow.

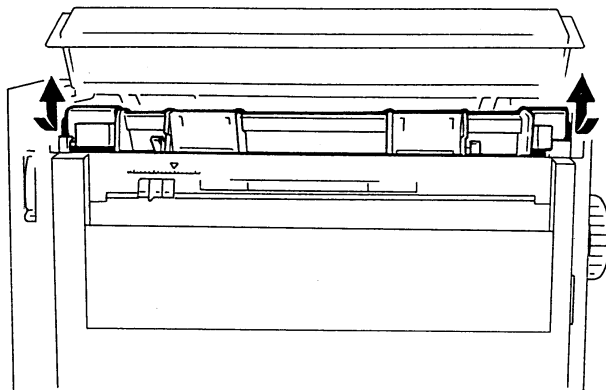

---

# Commands

---

This appendix provides information about the commands supported by your printer. The commands are organized by function groups. Each command has both a brief and a detailed description.

<b>Introduction .....</b>	<b>D.2</b>
General Overview .....	D.2
Command Summary .....	D.2
<b>Command Description.....</b>	<b>D.7</b>
Setting Form Length.....	D.7
Setting Margins.....	D.8
Setting Spacings .....	D.9
Setting Tabulations .....	D.12
Paper Movements .....	D.18
Character Set Selection.....	D.20
Automatic Sheet Feeder Commands .....	D.22
Printing Dot Graphics.....	D.23
Setting Down-line Loading .....	D.25
Bar Code Commands.....	D.28
Miscellaneous .....	D.32

# Introduction

## General Overview

---

This section is designed for technical users that wish to program the printer's operation. It describes the control commands that can be included in the data sent to the printer. The commands described in this section are grouped according to their functions. Some commands control paper feeding while others allow the programmer to select printing attributes.

Each command has the following structure:

- ◆ Name and function description. Information about protocol (Proprinter, EPSON and IBM).
- ◆ The hexadecimal and decimal codes for the command; the symbol ( #) represents variable parameters of the command. The functions of these parameters are explained in the corresponding command description.

## Command Summary

---

ESC C {n}	Sets form length in number of lines.	A.6
ESC C NUL {n}	Sets form length in inches.	A.6
ESC N {n}	Set bottom of form (skip over perforation).	A.6
ESC O	Cancels skip-over perforation.	A.6
ESC l {n}	Sets left margin (only EPSON mode).	A.7
ESC Q {n}	Sets the right margin (only EPSON mode).	A.7
ESC X {n} {m}	Sets left and right margins (only IBM mode).	A.7
ESC 4	Sets top of form (only IBM mode).	A.7
ESC P	Sets horizontal spacing to 10 or 17 cpi (only EPSON mode).	A.8
ESC M	Sets horizontal spacing to 12 or 20 cpi (only EPSON mode).	A.8
ESC :	Sets horizontal spacing to 12 cpi (only IBM mode).	A.8
ESC g	Sets horizontal spacing to 15 cpi (only EPSON mode).	A.8
SI or ESC SI	Selects compressed printing.	A.8
DC2	Resets compressed spacing.	A.9
ESC p {n}	Sets or cancels proportional printing (only EPSON mode).	A.9
ESC P {n}	Sets or cancels proportional printing (only IBM mode).	A.9
ESC A {n}	Sets variable vertical spacing.	A.9
ESC 2	Sets vertical spacing to default value.	A.9
ESC 0	Sets vertical spacing to 1/8 inch.	A.10
ESC 1	Sets vertical spacing to 7/72 inch (only IBM mode).	A.10
ESC 3 {n}	Sets vertical spacing to n/216 or n/180 inch.	A.10
ESC + {n}	Sets vertical spacing to n/360 inch (only EPSON mode).	A.10
ESC D {n1}...{nx} NUL	Sets horizontal tab stops	A.10
HT	Moves logically the print carriage to next horizontal tab stop.	A.11
ESC B {n1}...{nx} NUL	Sets vertical tab stops.	A.11
ESC B NUL	Cancels all current vertical tab stops.	A.11

ESC b {m} {n1}... NUL	Sets vertical tab stop in one of the 8 Vertical Format Unit (VFU) channels available (EPSON mode).	A.11
ESC / {m}	Select the Vertical Format Unit (VFU) channel (only EPSON mode)	A.12
VT	Advances paper to the next vertical tap stop of the selected VFU channel.	A.12
ESC b {m} NUL	Cancels all current vertical tab stops set in the specific VFU channel (only EPSON mode).	A.12
ESC R	Sets horizontal and vertical tab stops to default values (only IBM mode).	A.12
SO or ESC SO	Sets double width printing.	A.13
DC4	Cancels double width printing.	A.13
ESC W {n}	Sets or cancels double width printing.	A.13
ESC [ @ {l} {h} {m1}...{m4}	Changes height and width of characters and modifies vertical spacing appropriately (only IBM mode).	A.13
ESC w {n}	Sets or cancels double high printing (only EPSON mode).	A.14
ESC E	Sets emphasized printing.	A.14
ESC F	Cancels emphasized printing.	A.14
ESC G	Sets double strike printing.	A.15
ESC H	Cancels double strike printing.	A.15
ESC S {n}	Sets subscript or superscript printing.	A.15
ESC T	Cancels subscript or superscript printing.	A.15
ESC 4	Sets italics printing (only EPSON mode).	A.15
ESC 5	Cancels italics printing (only EPSON mode).	A.15
ESC - {n}	Sets or cancels underlined printing.	A.15
ESC _ {n}	Sets or cancels overscore printing (only IBM mode).	A.16
ESC q {n}	Select character style (only EPSON mode)	A.16
ESC ! {n}	Select printing mode (only EPSON mode).	A.16
ESC ( -	Select the score line (only EPSON mode).	A.17
LF	Advances paper one line.	A.17
ESC 5 {n}	Sets an automatic line feed after a carriage return (only IBM mode).	A.18
FF	Advances paper to the top of next page.	A.18
ESC J {n}	Advances paper n/216 or n/180 inch.	A.18
ESC j {n}	Reverses paper n/180 inch (only EPSON mode).	A.18
ESC 7	Selects Character Set 1.	A.18
ESC 6	Selects Character Set 2.	A.19
ESC t {n}	Selects Character table (only EPSON mode).	A.19
ESC R {n}	Selects national character set (only EPSON mode).	A.19
ESC k {n}	Selects character typestyle.	A.20
ESC [ T	Selects code page (only IBM mode).	A.20
ESC EM {n}	Ejects single sheet and selects/deselects the ASF (only EPSON mode).	A.20
ESC EM R	Ejects paper and disables printer (offline) once (only EPSON mode).	A.21
ESC K {n1} {n2} {p1}...{px}	Prints normal density dot graphics (60 dpi).	A.21
ESC L {n1} {n2} {p1}...{px}	Prints double density dot graphics at half speed (120 dpi).	A.22
ESC Y {n1} {n2} {p1}...{px}	Prints double density dot graphics at normal speed (120 virtual dpi).	A.22
ESC Z {n1} {n2} {p1}...{px}	Prints quadruple density dot graphics (240 virtual dpi).	A.22
ESC * {m} {n1} {n2} {p1}...{px}	Sets dot graphics mode (EPSON LQ and IBM Proprinter XL24 AGM modes).	A.22
ESC [ g {l} {h} {m}{n1}...{nk}	Selects 8/ 24 needle dot graphics mode (only IBM mode).	A.23

ESC ? {n} {m}	Reassign the graphics mode.(only EPSON mode)	A.24
ESC : NUL {n} NUL	Copies the character generator in ROM to RAM (only EPSON mode)	A.24
ESC & NUL {n}{m}{w0}{w1}{w2}{d0}... {dn} {w0}..	Defines down-line loaded characters (only EPSON mode).	A.25
ESC % {1}	Selects the use of downloaded character set in RAM (only EPSON mode).	A.25
ESC % {0}	Re-selects the character generator in ROM (only EPSON mode).	A.26
ESC = {n} {m} {35} {p} {q}	Defines down-line loaded character (only IBM mode).	A.26
BEL	Sounds the buzzer.	A.28
BS	Moves the printer carriage one character to the left.	A.28
CAN	Cancel data on same line.	A.28
DEL	Deletes last character sent (only EPSON mode).	A.28
CR	Causes all received data to be printed out.	A.28
DC 1	Selects printer.	A.29
DC 3	Deselects printer (only EPSON mode).	A.29
ESC Q {35} {36}	Deselects printer (only IBM mode).	A.29
ESC x {n}	Selects Quality or Draft printing (only EPSON mode).	A.29
ESC I {n}	Selects printing mode (only IBM mode).	A.29
ESC \ {n} {m}	Prints characters from IBM PC Character Set (only IBM mode).	A.30
ESC ^ {n}	Prints one character from IBM PC Character Set (only IBM mode).	A.30
ESC U {n}	Sets and cancels monodirectional printing.	A.31
ESC <	Prints characters from left to right for only one line (only EPSON mode).	A.31
ESC @	Re-initializes the printer (only EPSON mode).	A.31
ESC   K {n1}{n2}{init}{id}{parm1} {pamr2}	Sets the initial condition (only IBM mode).	A.31
ESC >	Set the 8th bit of the byte to 1 (only EPSON mode).	A.33
ESC =	Set the 8th bit of the byte to 0 (only EPSON mode).	A.33
ESC #	Cancel Most Significant Bit control (only EPSON mode).	A.33
ESC SP {n}	Sets intercharacter space (only EPSON mode).	A.34
ESC \$ {n} {m}	Sets absolute dot position (only EPSON mode).	A.34
ESC \ {n} {m}	Sets relative dot position (only EPSON mode).	A.34
ESC d {n} {m}	Spaces forwards relative dot position only(only IBM mode).	A.34
ESC e {n} {m}	Spaces backwards relative dot position (only IBM mode).	A.35
ESC [ \ {l} {h} {m1}...{m4}	Sets vertical units (only IBM mode).	A.35
ESC j	Stops printing (only IBM mode).	A.35



## Commands Description

### Setting Form Length

---

**ESC C {n}**      *Sets form length in number of lines.*

1B 43 {n}  
27 67 {n}  
 $1 \leq n \leq 127$

This command sets the form length to the number of lines specified by {n} at the current vertical spacing. The form length is memorized as physical position on the page. The current paper position is assumed as top of the form.

---

**ESC C NUL {n}**      *Sets form length in inches.*

1B 43 00 {n}  
27 67 0 {n}  
 $1 \leq n \leq 22$

This command sets the form length to the number of inches specified by {n}. The current position of the paper is assumed as top of form.

---

**ESC N {n}**      *Set bottom of form (skip over perforation).*

1B 4E {n}  
27 78 {n}  
 $1 \leq n \leq 255$

This sequence sets the number of lines {n} to be skipped at the bottom of a page. {n} must be less than the current form length. The bottom of form distance is memorized as physical position on the page. This can be reset by the ESC O command or by changing the form length setting.

---

**ESC O**      *Cancels skip-over perforation.*

1B 4F  
27 79

This sequence sets the number of lines of skip perforation to {0}.

## Setting Margins

---

**ESC I {n}**      *Sets left margin (only EPSON mode).*

**1B 6C {n}**  
**27 108 {n}**  
 $0 \leq n \leq 229$

This code sets the left margin at the current horizontal spacing. It must be sent at the beginning of the line. {n} is the number of columns. The left margin must be smaller than the right margin.

---

**ESC Q {n}**      *Sets the right margin (only EPSON mode).*

**1B 51 {n}**  
**27 81 {n}**  
 $1 \leq n \leq 255$

This code specifies the line length required at the current horizontal spacing. It must be sent at the beginning of the line. {n} is the number of columns and for each type of horizontal spacing there is a range of values. The right margin must be greater than the left margin.

---

**ESC X {n} {m}**      *Sets left and right margins (only IBM mode).*

**1B 58 {n} {m}**  
**27 88 {n} {m}**  
 $0 \leq n \leq 255$   
 $0 \leq m \leq 255$

This command sets the left and right margins simultaneously. The {n} and {m} parameters indicate respectively the number of columns for the left and right margin at the current horizontal spacing. These margins are memorized in terms of absolute displacement from the physical left edge of the page. If {n} is equal to 0, the current left margin value is used. If {m} is equal to 0, the current right margin is used.

---

**ESC 4**      *Sets top of form (only IBM mode).*

**1B 34**  
**27 52**

This sequence sets the current paper position as top of form that is first printable line.

## Setting Spacings

---

**ESC P**            *Sets horizontal spacing to 10 or 17 cpi (only EPSON mode)*

**1B 50**  
**27 80**

Terminator code. The spacing is set to 17 cpi if the compressed printing has been previously selected by SI or ESC SI command.

---

**ESC M**            *Sets horizontal spacing to 12 or 20 cpi (only EPSON mode.)*

**1B 4D**  
**27 77**

Terminator code. The spacing is set to 20 cpi if the compressed printing has been previously selected by SI or ESC SI command.

---

**ESC :**            *Sets horizontal spacing to 12 cpi (only IBM mode).*

**1B 3A**  
**27 58**

Terminator code.

---

**ESC g**            *Sets horizontal spacing to 15 cpi (only EPSON mode)*

**1B 67**  
**27 103**

Terminator code. Compressed printing cannot be combined with 15 cpi.

---

**SI or ESC SI**    *Selects compressed printing.*

**0F or 1B 0F**  
**15 or 27**

Terminator code. In IBM mode, this command sets horizontal spacing to 17 cpi (compressed spacing), if 10 cpi has been previously set; otherwise it is ignored. In EPSON mode, the setting of this command depends on the horizontal spacing previously set: 10 cpi is changed into 17 cpi, 12 cpi is changed into 20 cpi

---

---

**DC2**                    *Resets compressed spacing.***12 or 1B 12**  
**18 or 27**

Terminator code. In IBM mode, the compressed horizontal 18 spacing is reset to 10 cpi. In EPSON mode, the 17 cpi compressed spacing is reset to 10 cpi while the 20 cpi compressed spacing is reset to 12 cpi.

---

**ESC p {n}**            *Sets or cancels proportional printing (only EPSON mode).***1B 70 {n}**  
**27 112 {n}**

Terminator code. If {n} = {1}, proportional printing is set. If {n} = {0r}, proportional printing is reset.

---

**ESC P {n}**            *Sets or cancels proportional printing (only IBM mode).***1B 50 {n}**  
**27 80 {n}**  
**0 ≤ n ≤ 255**

Terminator code. If {n} = {odd number}, proportional printing is set. If {n} = {even number}, proportional printing is reset.

---

**ESC A {n}**            *Sets variable vertical spacing.***1B 41 {n}**  
**27 65 {n}**  
**0 ≤ n ≤ 85**

This command changes the default vertical spacing to n/60 inch (EPSON LQ and IBM Proprinter XL24 AGM modes) or n/72 inch (IBM Proprinter XL24 mode).

---

**ESC 2**                    *Sets vertical spacing to default value.***1B 32**  
**27 50**

In IBM Proprinter XL24 mode, the default vertical spacing is either the value specified by a previous ESC A command or the value previously set via Printer Setup procedure.

In IBM Proprinter XL24 AGM mode, this command has no effect. In EPSON mode, the default vertical spacing is 1/6 inch.

---

<b>ESC 0</b>	<b><i>Sets vertical spacing to 1/8 inch.</i></b> 1B 30 27 48
--------------	--

---

<b>ESC 1</b>	<b><i>Sets vertical spacing to 7/72 inch (only IBM mode).</i></b> 1B 31 27 49
--------------	---

---

<b>ESC 3 {n}</b>	<b><i>Sets vertical spacing to n/216 or n/180 inch.</i></b> 1B 33 {n} 27 51 {n} 1 ≤ n ≤ 255 (IBM Proprinter XL24 emulation) 0 ≤ n ≤ 255 (IBM Proprinter XL24 AGM and EPSON LQ emulations)
------------------	---

In IBM Proprinter XL24 emulation, the vertical spacing is set to n/216 or n/180 inch according to the ESC [ \ setting; if ESC [ \ has not been sent, the vertical spacing is set to n/216 inch.

In IBM Proprinter XL24 AGM and EPSON LQ emulations, the vertical spacing is set to n/180 inch.

---

<b>ESC + {n}</b>	<b><i>Sets vertical spacing to n/360 inch (only EPSON mode).</i></b> 1B 2B {n} 27 43 {n} 0 ≤ n ≤ 255
------------------	---

## *Setting Tabulations*

---

<b>ESC D {n1}..{nx} NUL</b>	<b><i>Sets horizontal tab stops</i></b>
-----------------------------	---

1B 44 {n1}...{nx} 00  
27 68 {n1}...{nx} 0  
0 ≤ n ≤ 255

This sequence sets up to 32 (EPSON mode) or 28 (IBM mode) horizontal tab stops after cancelling the current setting. {n1} to {nx} specify the number of columns at which horizontal tab stops are required and must be entered in the sequence in ascending numerical order.

---

**HT*****Moves logically the print carriage to next horizontal tab stop.*****09 or 1B 09  
9 or 27 9**

---

**ESC B {n1}...{nx} NUL*****Sets vertical tab stops.*****1B 42 {n1}...{nx} 00  
27 66 {n1}...{nx} 00  
 $1 \leq n \leq 255$** 

---

Sets vertical tab stops in the 0 Vertical Format Unit (VFU) channel (EPSON mode). In IBM mode, this code sets up to 64 vertical tab stops at the line number specified by {n1}, {n2} and so on. The tab stops are memorized as logical positions.

In EPSON mode, this code sets up to 16 vertical tab stops at the line specified by {n1}, {n2} and so on in the 0 VFU channel. The tab stops are memorized as physical positions.

---

**ESC B NUL**  ***Cancels all current vertical tab stops.*****1B 42 00  
27 66 0**

---

**ESC b {m} {n1}... NUL*****Sets vertical tab stop in one of the 8 Vertical Format Unit (VFU) channels available (EPSON mode).*****1B 62 {m} {n1}.. 00  
27 98 {m} {n1}.. 0  
 $0 \leq m \leq 7$   
 $1 \leq n \leq 255$** 

---

This sequence sets vertical tabulations in the VFU channel specified by the parameter {m}. Eight channels are available and in each of them you can create a sample page that you can recall

Up to 16 tab stops can be set in each channel at the line specified by {n1}, {n2} and so on in numerical ascending order. To clear the tabs in channel {n} use ESC b {m} NUL

---

**ESC / {m}**      *Select the Vertical Format Unit (VFU) channel (only EPSON mode)*

1B 2F {m}.  
27 47 {m}  
0 ≤ m ≤ 7

The {m} parameter specifies the VFU channel number.

---

**VT**              *Advances paper to the next vertical tab stop of the selected VFU channel.*

0B  
11

In IBM mode, this code will be executed like a LF code, if the tab stop follows the bottom of form position or if the current position is beyond the last tab stop or if no tab stop has been sent by the ESC B. In EPSON mode, the vertical tabulations that should be executed are referred to the VFU channel selected by the ESC / {m} command. If no VFU channels have been selected, the printer assumes as default the channel 0. This code will be executed like a FF code if the tab stop follows the bottom of form position or if the current position is beyond the last tab stop. It will be executed like a LF code, if no tab stop has been set. If the vertical tabulations have been reset, the LF will be not executed.

---

**ESC b {m} NUL**       *Cancels all current vertical tab stops set in the specific VFU channel (only EPSON mode).*

1B 62 {m} 00  
27 98 {m} 0  
0 ≤ m ≤ 7

The {m} parameter specifies the VFU channel number.

---

**ESC R**              *Sets horizontal and vertical tab stops to default values (only IBM mode).*

1B 52  
27 82

This command sets horizontal tab stops every eight columns starting from column 9, and cancels all vertical tab stops.

## Setting Print Attributes

---

### SO or ESC SO

*Sets double width printing.*

0E or 1B 0E

14 or 27 14

---

### DC4

*Cancels double width printing.*

14

20

---

### ESC W {n}

*Sets or cancels double width printing.*

1B 57 {n}

27 87 {n}

---

In IBM mode, if {n} = {odd number}, double width printing is set. If {n} = {even number}, double width printing is reset, the range is  $0 \leq n \leq 255$ . In EPSON mode if {n} = {1}, double width printing is set. If {n} = {0}, double width printing is reset.

---

### ESC [ @ {l} {h} {m1}...{m4}

*Changes height and width of characters and modifies vertical spacing appropriately (only IBM mode).*

1B 5B 40 {l} {h} {m1}...{m4}

27 91 64 {l} {h} {m1}...{m4}

The {l} and {h} parameters specify the number of {mx} mode bytes contained in the sequence (normally l=4 and h=0). The {m1} and {m2} parameters must be equal to 0. The {m3} and {m4} parameters specify the printing characteristics.

The {m3} high nibble specifies the line feed multiplier; {m3} low nibble specifies the height multiplier .

---

<b>m3</b>	<b>Selection</b>
00	No change
01	Standard character height
02	Double character height
16	Single line feed, no change
17	Single line feed, standard character height
18	Single line feed, double character height
32	Double line feed, nh change
33	Double line feed, standard character height
34	Double line feed, double character height

The {m4} high nibble is discarded; the {m4} low nibble specifies the width multiplier:

<b>m4</b>	<b>Selection</b>
00	No change
01	Standard character width
02	Double character width

---

**ESC w {n}**      *Sets or cancels double high printing (only EPSON mode).*

**1B 77 {n}**  
**27 119 {n}**

In IBM mode, if {n} = {odd number}, double height printing is set. If {n} = {even number}, double height printing is reset, the range is  $0 \leq n \leq 255$ . In EPSON mode if {n} = {1}, double height printing is set. If {n} = {0}, double height printing is reset.

---

**ESC E**      *Sets emphasized printing.*

**1B 45**  
**27 69**

---

**ESC F**      *Cancels emphasized printing.*

**1B 46**  
**27 70**

---

**ESC G**            *Sets double strike printing.*

1B 47  
27 71

---

**ESC H**             *Cancels double strike printing.*

1B 48  
27 72

---

**ESC S {n}**        *Sets subscript or superscript printing.*

1B 53 {n}  
27 83 {n}

In IBM mode if {n} = {odd number}, subscript printing is set.. If {n} = {even number}, superscript printing is set. In EPSON mode if {n} = {1}, subscript printing is set.. If {n} = {0}, superscript printing is set.

---

**ESC T**             *Cancels subscript or superscript printing.*

1B 54  
27 84

---

**ESC 4**            *Sets italics printing (only EPSON mode) .*

1B 34  
27 52

---

**ESC 5**             *Cancels italics printing (only EPSON mode).*

1B 35  
27 53

---

**ESC - {n}**        *Sets or cancels underlined printing.*

1B 2D {n}  
27 45 {n}

In IBM mode if {n} = {odd number}, underlined printing is set. If {n} = {even number}, underlined printing is reset. In EPSON mode if {n} = {1}, underlined printing is set. If {n} = {0}, underlined printing is reset.

---

**ESC \_ {n}**      *Sets or cancels overscore printing (only IBM mode).*

1B 5F {n}  
 27 95 {n}  
 0 ≤ n ≤ 255

If {n} = {odd number}, overscore printing is set. If {n} = {even number}, overscore printing is reset.

---

**ESC q {n}**      *Select character style (only EPSON mode)*

1B 71 {n}  
 27 113 {n}  
 0 ≤ n ≤ 255

This command is valid for all characters. See the following table:

n	Character Style
0	Normal
1	Outline
2	Shadow
3	Outline with Shadow

---

**ESC ! {n}**      *Select printing mode (only EPSON mode).*

1B 21 {n}  
 27 33 {n}  
 0 ≤ n ≤ 255

This code selects printing attribute combinations. See the following table:

n	Attribute
0	10 cpi
1	12 cpi
2	Proportional
4	Compressed
8	Emphasized
16	Double strike
32	Double width
64	Italics
128	Underline

---

---

**ESC ( -**      *Select the score line (only EPSON mode).*

**1B 28 2D** {n1}{n2} {m} {d1} {d2}  
**27 40 45** {n1}{n2} {m} {d1} {d2}  
**0 ≤ n ≤ 255**

The parameters in the command have the following meaning:

n1	must be 3
n2	must be 0
m	must be 1

The parameter {d1} determines the location of the score:

<b>d1</b>	<b>Location</b>
1	Underline
2	Strike-through
3	Overscore

The parameter {d2} determines the style of the score:

<b>d2</b>	<b>Style</b>
0	Cancel the score line selected by d1
1	Single continuous line
2	Double continuous line
5	Single broken line
65	Double broken line

## *Paper Movements*

---

**LF**      *Advances paper one line.*

**0A or 1B 0A**  
**10 or 27 10**

Terminator code. It advances paper one line at the current vertical spacing. In IBM mode, the column counter is set to the left margin value if the automatic carriage return has been selected. In EPSON mode, the column is always set to the left margin value.

---

**ESC 5 {n}**      *Sets an automatic line feed after a carriage return (only IBM mode).*

1B 35 {n}  
27 53 {n}  
0 ≤ n ≤ 255

If {n} is equal to {odd number}, this command sets an automatic line feed on receiving a CR code. If {n} is equal to {even number}, this command cancels the automatic line feed.

---

**FF**      *Advances paper to the top of next page.*

0C or 1B 0C  
12 or 27 12

Terminator code. It advances the paper to the first printable line of the next form.

---

**ESC J {n}**      *Advances paper n/216 or n/180 inch.*

1B 4A {n}  
27 74 {n}  
1 ≤ n ≤ 255

Terminator code. In IBM Proprinter XL24 mode, the paper advances n/216 or n/180 inch according to ESC { \ setting; otherwise, the paper will be advanced n/216 inch. The column counter will be set to the left margin value if automatic carriage return has been selected. In EPSON LQ and IBM Proprinter XL24 AGM modes, the paper advances n/180 inch.

---

**ESC j {n}**      *Reverses paper n/180 inch (only EPSON mode).*

1B 6A {n}  
27 106 {n}  
1 ≤ n ≤ 255

Terminator code. The paper reverses n/180 inch without any resetting of the column counter.

## *Character Set Selection*

---

**ESC 7**      *Selects Character Set 1.*

1B 37  
27 55

---

**ESC 6**      *Selects Character Set 2.***1B 36**  
**27 54**

---

**ESC t {n}**      *Selects Character table (only EPSON mode).***1B 74 {n}**  
**27 116 {n}**  
**0 ≤ n ≤ 2**

If {n} is equal to {0}, this code selects the EPSON Standard Italic Character set.  
If {n} is equal to {1}, this code selects the IBM Standard extended Character Set.  
If {n} is equal to {2}, this code remaps DLL characters from position 0-127 to position 128-255.

---

**ESC R {n}**      *Selects national character set (only EPSON mode).***1B 52 {n}**  
**27 82 {n}**  
**0 ≤ n ≤ 12**

This code causes subsequent data to be printed using the national character set selected by {n}, as follows:

<b>n</b>	<b>Nation</b>
0	USA-IBM PC Compatible
1	France
2	Germany
3	United Kingdom
4	Denmark-1
5	Sweden
6	Italy
7	Spain-1
8	Japan
9	Norway
10	Denmark-2
11	Spain -2
12	Latin -America
13	Korea
64	Legal

**ESC k {n}**      *Selects character typestyle.*

**1B 6B {n}**  
**27 107 {n}**  
**0 ≤ n ≤ 255**

This sequence allows you to select the typestyle. The {n} parameter specifies the typestyle number. See the following table:

<b>n</b>	<b>Font</b>
0	Roman
1	San Serif
2	Courier
3	Prestige
4	Script
5	Gothic
6	Bold PS

**ESC [ T**      *Selects code page (only IBM mode).*

**1B 5B 54 {n1} ....{n6}**  
**27 91 84 {n1} ....{n6}**

This sequence allows the printer to change the ID of the current code page. If an unavailable code page is specified, this command is ignored.

*Automatic Sheet Feeder Commands***ESC EM {n}**      *Ejects single sheet and selects or deselects the Automatic Sheet Feeder (only EPSON mode).*

**1B 19 {n}**  
**27 25 {n}**  
**n = 0,1,2,4**

This sequence performs different functions according to {n} parameter:

<b>n</b>	<b>Function</b>
0	ASF disabled and printer (offline) after paper ejection
1	Bin 1
4	ASF enabled)

When the ASF is enabled, paper is loaded when the printer receives a string of data or the CR, LF, VT or FF codes. The reception of a FF code when the paper is already loaded, however, causes the paper to be ejected (the same action as FORM FEED key).

---

**ESC EM R**     *Ejects paper and disables printer (offline) once (only EPSON mode).*

**1B 19 52**  
**27 25 82**

## *Printing Dot Graphics*

---

**ESC K {n1} {n2} {p1}...{px}**  
*Prints normal density dot graphics (60 dpi).*

**1B 4B {n1} {n2} {p1}...{px}**  
**27 75 {n1} {n2} {p1}...{px}**  
**0 ≤ n1 ≤ 255**  
**0 ≤ n2 ≤ 3**

Terminator code This command prints dot graphics at 60 horizontal dot per inch. The parameter values should be calculated as follows:

<b>n1</b>	remainder of the number of columns divided by 256
<b>n2</b>	integer result of the previous division
<b>p1</b>	sum of the values corresponding to the dots that should be printed in the first column of the graphics pattern
<b>p2</b>	sum of the values corresponding to the dots that should be printed in the second column of the graphics pattern
<b>px</b>	sum of the values corresponding to the dots that should be printed in the last column of the graphics pattern

In IBM Proprinter XL24 emulation, 8 dot data are simulated by 20 of the 24 print head needles.

In IBM Proprinter XL24 AGM and EPSON LQ emulations, 8 dot data are simulated by 24 print head needles.

---

**ESC L {n1} {n2} {p1}...{px}**

*Prints double density dot graphics at half speed (120 dpi).*

1B 4C {n1} {n2} {p1}...{px}

27 76 {n1} {n2} {p1}...{px}

0 ≤ n1 ≤ 255

0 ≤ n2 ≤ 6

Terminator code. See ESC K description.

---

**ESC Y {n1} {n2} {p1}...{px}**

*Prints double density dot graphics at normal speed (120 virtual dpi).*

1B 59 {n1} {n2} {p1} {p2}...{px}

27 42 {n1} {n2} {p1} {p2}...{px}

0 ≤ n1 ≤ 255

0 ≤ n2 ≤ 6

Terminator code. See ESC K description.

---

**ESC Z {n1} {n2} {p1}...{px}**

*Prints quadruple density dot graphics (240 virtual dpi).*

1B 5A {n1} {n2} {p1} {p2}...{px}

27 90 {n1} {n2} {p1} {p2}...{px}

0 ≤ n1 ≤ 255

0 ≤ n2 ≤ 12

Terminator code. See ESC K description.

---

**ESC \* {m} {n1} {n2} {p1}...{px}**

*Sets dot graphics mode (EPSON LQ and IBM Proprinter XL24 AGM modes).*

1B 2A {m}{n1}{n2} {p1}...{px}

27 42 {m}{n1}{n2} {p1}...{px}

m=0,1,2,3,4,5,6,32,33,38,39,40

0 ≤ n1 ≤ 255

0 ≤ n2 ≤ 12

Terminator code. The following table shows you the available 8 needle dot graphics modes (EPSON LQ mode):

<b>m</b>	<b>Mode</b>	<b>dpi</b>
0	Normal density	60
1	Dual density	120
2	Dual speed, dual density	120 (virtual)
3	Quadruple density	240 (virtual)
4	CRT Graphics I	80
6	CRT Graphics II	90

The following table shows you the 24 needles dot graphics modes available on your printer (EPSON LQ and IBM Proprinter XL24 AGM modes):

<b>m</b>	<b>Mode</b>	<b>dpi</b>
32	Single density	60
33	Double density	120
38	CRT Graphics III	90
39	Triple density	180
40	Hex density	360 (virtual)

---

## **ESC [ g {l} {h} {m}{n1}...{nk}**

*Selects 8 or 24 needle dot graphics mode (only IBM mode).*

**1B 5B 67 {l} {h} {m} {n1}...{nk}**  
**27 91 103 {l} {h} {m} {n1}...{nk}**

This command selects dot graphics in 8 or 24 needle configuration. {h}\*256+{l} represents the {number of data + 1}. The {m} parameter represents the dot graphics modes as shown in the following table:

<b>m</b>	<b>Density</b>	<b>Needle</b>	<b>Function</b>
0	60	8	Same as ESC K (8 needles)
1	120	8	Same as ESC L (8 needles)
2	120	8	Same as ESC Y (8 needles)
3	240	8	Same as ESC Z (8 needles)
8	60	24	High Resolution for ESC K
9	120	24	High Resolution for ESC L

The {n1}, {n2} up to {nk} parameters are dot graphics data. If you select the 8 needle dot graphics mode, one byte data is needed for each column so that the formulas  $\{h\} * 256 + \{1\} = \{\text{number of columns}\} + \{1\}$  is valid. If you select the 24 needle dot graphics mode, three bytes data are needed for each column so that the formulas  $\{h\} * 256 + \{1\} = \{\text{number of columns} * 3\} + \{1\}$  is valid.

---

## ESC ? {n} {m}

*Reassign the graphics mode. (only EPSON mode)*

**1B 3F {n} {m}**

**27 63 {n} {m}**

This command changes one graphics mode to another. The parameter {n} specifies a character (K, L, Y or Z) which is reassigned to specific mode {m} = 0-6, 32-33, 38-40

## Setting Down-line Loading

---

### ESC : NUL {n} NUL

*Copies the character generator in ROM to RAM (only EPSON mode)*

**1B 3A 00 {n} 00**

**27 58 0 {n} 0**

This sequence copies the character generator in ROM into the RAM area dedicated to the down-line loading of characters. Make sure that the BUFFER FULL function is selected in the Printer Setup, otherwise this command will be ignored. The {n} parameter specifies the font number as follows:

<b>n</b>	<b>Font</b>
0	Roman
1	San Serif
2	Courier
3	Prestige
4	Script
5	Gothic
6	Bold PS

---

**ESC & NUL {n}{m}{w0}{w1}{w2}{d0}... {dn}  
{w0}..**

*Defines down-line loaded characters (only EPSON mode).*

**1B 26 00 {n} {m} {w0} {w1} {w2} {d0} ..... {dn} {w0}**  
**27 38 0 {n} {m} {w0} {w1} {w2} {d0} ..... {dn} {w0}**

The down-line loading of characters is the printer feature which allows the definition of special characters not present in the character sets. Do not forget to select the BUFFER FULL function in the Printer Setup procedure. The parameters in the command have the following meaning:

{n} {m} are the two decimal numbers that define the first and the last characters to be replaced in the character set in use. If you want to replace only one character, {m} must be equal to {n}. Any value in the range {0} to {127} will be accepted even if it is advisable not to define the code {32}, which is the space character.

{w0} are the numbers that specify the width of the character and the space around it. The space on the left of the character (in dots column) is specified by {w0} while the space on the right of the character is specified by {w2}. The {w1} parameter specifies the number of columns of dots that must be printed to design the character.

See the following table for the maximum value of {w0}, {w1}, {w2}:

<b>Printing</b>	<b>{w0}+{w1}</b>	<b>{w0}+{w1}+{w2}</b>
Draft	9	12
Quality at 10 cpi	35	36
Quality at 12 cpi	29	30
Proportional	41	42

d0..dn are the data of the character that is printed. Three bytes are needed for each column because it is composed of 24 dot positions. In this way, the number of data bytes is {w1} \* 3. You can define character in superscript or subscript printing, two bytes are needed for each column because it is composed by 16 dot positions; the number of data bytes is {w1} \* 2.

---

**ESC % {1}**

*Selects the use of downloaded character set in RAM (only EPSON mode).*

**1B 25 {01}**  
**27 37 {1}**

This sequence selects the use of the redefined character(s) in RAM according to the current selection.

---

**ESC % {0}**      *Re-selects the character generator in ROM (only EPSON mode).*

1B 25 {00}  
27 37 {0}

This sequence causes downloaded character redefinitions to be ignored and selects the character generator in the ROM.

---

**ESC = {n} {m} {35} {p} {q}**      *Defines down-line loaded character (only IBM mode).*

1B 3B {n} {m} {23} {p} {q}  
27 61 {n} {m} {35} {p} {q}

This sequence allows to design and then down-line load special character not present in the character set in use. It also allows to change one character with another character. Do not forget to select BUFFER FULL function in the Printer Setup. Whenever you would like to start the DLL setting procedure, proceed as follows:

- ◆ copy the character generator in ROM into RAM
- ◆ select the DLL generator.

256 entries of 9 bytes compose the look up table of a character generator. One entry describes one character as follows:

Byte 1,2	The absolute address of the character definition	
Byte 3		
Bit 7	{1}	indicates that the character is a graphic character (connects at 6 lpi)
	{0}	indicates that the character is an alphanumerical character
Bit 6	{0}	indicates a DLL character
	{1}	indicates a resident character
Bit 5 to 0	these 6 bits indicate the effective number of dot columns of the character shape stored in memory	
Byte 4		
Bit 7,6	Graphic character description:	
	{00}	shading character
	{01}	line drawing character
	{10}	underscored character

	{11}	not supported
		All graphic characters are 30 dot high, even though only 24 dots are defined for each column. An underscored character is defined as a blank graphic character (all zeros) and it is automatically generated by the printer. A shading character repeats dots 1-6 of each column as dots 25 through 30 respectively. A line drawing character repeats dots 23 and 24 as the pairs 25 and 26, 27 and 28, and 29 and 30.
Bit 5 to 0		The number of dot columns of the character shape minus one. For example: the character width of Draft generator is 10 dots and bit 5 to 0 must be set to {9}
Bit 5 to 9		Compression mask description. It is used to optimize the memory occupation and it is based on the concept that a dot column equal to the dot column on its left is not stored. You can calculate the compression mask of a character only after designing the entire character. Every bit is associated with a dot column with the bit 7 of byte 5 associated with the leftmost column. The bit is set to {1}, if the column is equal to the preceding one; otherwise, it is set to {0}. If the character is longer than 39 dot columns, the remaining dot columns must be stored without compression. The bit 40 (bit 0 of byte 9) must be 0. If no compression is present in the character, byte 5 to 9 is composed by all zeros.

If you wish to copy an entry over another entry so that two characters with the same characteristics and different code are present in the same look up table, the DLL sequence ESC = {n} {m} {id} {p} {t} has the following meaning:

{n} and {m}	indicate the byte number of the sequence. {n} is the low part and {m} is the high part.
{id}	indicate the printer model. The {id} related to your printer is {23H}
{p} and {t}	indicate the memory address of the character that you wish to replace. {p} is the low part and {t} is the high part.
{data}	is the entry (9 bytes) of the character that you want to position at address specified by {p} and {t}.

## Miscellaneous

---

**BEL**                    *Sounds the buzzer.*  
                              07  
                              7

This command sounds the buzzer for about 1 seconds.

---

**BS**                    *Moves the printer carriage one character to the left.*  
                              08  
                              8

Terminator code. This code causes the printing to be continued from one column to the left of the current carriage position.

---

**CAN**                   *Cancels data on same line.*  
                              18  
                              24

This command causes the printer to delete data in the same line before the CAN code. Commands except SO and ESC SO are not affected.

---

**DEL**                  *Deletes last character sent (only EPSON mode).*  
                              7F  
                              127

This command causes the printer to delete the last character sent to the printer. This does not affect control codes.

---

**CR**                    *Causes all received data to be printed out.*  
                              0D  
                              13

Terminator code. The column counter is set to the left margin value and a line feed is inserted automatically after carriage return. A line feed may be added if the AUTOFEEDXT signal is held LOW and the AUTO XT function is selected in the Printer Setup.

---

---

**DC 1**                    *Selects printer.***11**  
**17**

In IBM mode, this command causes the printer to be enabled after it has been disabled by an ESC Q {35} command. In EPSON mode, this command causes the printer to be enabled after it has been disabled by DC3 code (the SELECTIN signal was HIGH). The SELECT signal goes high and the characters between DC3 and DC1 codes are discarded. If you selected SLCT IN (VALID set) in the Printer Setup, the DC1 code is ignored.

---

**DC 3**                    *Deselects printer (only EPSON mode).***13**  
**19**

If you send this command when the SELECTIN signal is high, it causes the printer to be disabled so that the SELECTIN signal goes low and the characters between DC3 and DC1 codes are discarded. If the SELECTIN signal is low or if you selected SLCT-IN (VALIDset) in the Printer Setup, the DC3 code is ignored.

---

**ESC Q {35} {36}**  
*Deselects printer (only IBM mode).***1B 51 {23}{24}**  
**27 81 {35}{36}**

This code causes the incoming data to be discarded until a DC1 code is received.

---

**ESC x {n}**                *Selects Quality or Draft printing (only EPSON mode).***1B 78 {n}**  
**27 120 {n}**

Terminator code. If n = {0} Draft printing is selected. If n = {1} Quality printing is selected. This setting overrides the operator panel selection.

---

**ESC I {n}**                *Selects printing mode (only IBM mode).***1B 49 {n}**  
**27 73 {n}**  
**0 ≤ n ≤ 22**

Terminator code. The printing mode, font and down-line loading of characters are selected according to the parameter setting. See the following table:

<b>n</b>	<b>Selection</b>
0	10 cpi Draft
2	10 cpi Quality
3	Proportional Quality
4	DLL 10 cpi Draft
6	DLL 10 cpi Quality
7	DLL Proportional Quality
8	12 cpi Draft
10	12 cpi Quality
12	DLL 12 cpi Draft
14	DLL 12 cpi Quality
16.	17 cpi Draft
18	17 cpi Quality
20	DLL 17 cpi Draft
22	DLL 17 cpi Quality

The setting of this command overrides any selection made from the operator panel.

---

**ESC \ {n} {m}** *Prints characters from IBM PC Character Set (only IBM mode).*

**1B 5C {n} {m}**

**27 92 {n} {m}**

**0 ≤ n ≤ 255**

**0 ≤ m ≤ 255**

This sequence specifies that subsequent characters are to come from the table of all printable characters (IBM PC Character Set). The {n} parameter specifies the remainder of the number of characters that you want to print divided by 256. The {m} parameter specifies the integer result of the number of characters that you want to print divided by 256. The control codes are not recognized as long as this sequence is active. The space character is printed as an unassigned character.

---

**ESC ^ {n}** *Prints one character from IBM PC Character Set (only IBM mode).*

**1B 5E {n}**

**27 94 {n}**

**0 ≤ n ≤ 255**

This sequence specifies that subsequent character {n} is to come from the table containing all the printable characters.

---

**ESC U {n}**     *Sets and cancels monodirectional printing.***1B 55 {n}****27 85 {n}**

In IBM, if the parameter {n} is equal to {odd number}, this sequence causes subsequent data to be printed monodirectionally, from left to right, instead of bidirectionally. To cancel monodirectional printing and return to bidirectional printing, {n} must be equal to {even number}. In EPSON, if the parameter {n} is equal to {1}, this sequence causes subsequent data to be printed monodirectionally, from left to right, instead of bidirectionally. To cancel monodirectional printing and return to bidirectional printing, {n} must be equal to {0}. When the printer is turned on, however, printing is performed bidirectionally.

---

**ESC <**     *Prints characters from left to right for only one line (only EPSON mode).***1B 3C****27 60**

This sequence causes subsequent characters to be printed from left to right (monodirectionally) for one line only. It is cancelled by a CR.

---

**ESC @**     *Re-initializes the printer (only EPSON mode).***1B 40****27 64**

This sequence causes the printer to be initialized. This command, inserted in the input buffer, will be executed during processing, so that data preceding this command will be printed according to previous setting. This code goes back to current Printer Setup setting, that is, the most recent values set, cancels any print attributes that have been set, initializes the printer carriage, resets the column counter, sets the horizontal tabulations every eight columns, clears all vertical tabulations set. Only the selection of Draft or Quality printing and the selected character generator are maintained.

---

**ESC [ K {n1}{n2}{init}{id}{parm1} {pamr2}**  
*Sets the initial condition (only IBM mode).***1B 5B 4B {n1} {n2} {init} {id} {parm1} {pam2}****27 91 75 {n1} {n2} {init} {id} {parm1} {pam2}**

This command causes the printer to reset to its initial status:

*{n1} and {n2}*

The *{n1}* and *{n2}* parameters specify the number of bytes in the escape sequence normally,

<b>n1</b>	1,3 or 4
<b>n2</b>	Always 0

*{init}*

The *{init}* parameter specifies to which condition the printer should initialize, normally *{init}* = 0,1,4, 5, 254 and 255. The first four values definitions affect the mode settings (i.e. quality, pitch or print mode) that can be selected via operator panel if no parameters are specified, however if the 0,1, or 256 values and the parameter(s) are specified, these ones overwrite the user function selection.

<b>init</b>	<b>Description</b>
0	Printer initialized to user default setting. Download font is not cleared
1	Printer initialized to user default setting. Download font is cleared
4	Printer initialized to factory default setting. Download font is not cleared
FE	Printer performs as value 1. Initialization results are saved and become the user default setting
FF	Printer performs as value 1. Initialization results are saved and become the user default setting

*{id}*

The *{id}* parameter specifies the printer for which the following parameter bytes are intended. If the ID does not address your printer, the mode bytes that follow are ignored.

*{parm1}*

The *{parm1}* parameter specifies which printer function is enable (on) or disable (off). These are the value definitions

<b>Bit</b>	<b>OFF</b>	<b>ON</b>
7 Discard byte	Process this byte	Ignore this byte
6 Reserved		
5 Alarm enable	Enable	Disable
4 Auto CR	No CR on vertical movement	CR on vertical movement

Bit	OFF	ON
3 Auto L	No LF with CR	Auto LF with CR
2 Form Length	11 inch form length	12 inch form length
1 Slashed Zero	Normal Zero	Select Slashed Zero
0 Character Set	Character Set 1	Character Set 2

{parm 2}

The {parm 2} parameter specifies which printer function is enable (on) or disable (off). These are the value definitions:

Bit	OFF	ON
7 Discard byte	Process this byte	Ignore this byte
6 Switch from USA to Multilingual font	Initialize download font area to USA font	Initialize download font area to Multilingual font
5 Reserved		
4 Reserved		
3 Reserved		
2 Reserved		
1 Line Length	13.6 inch print line	8 inch print line
0 Reserved		

---

**ESC >**                    *Set the 8th bit of the byte to 1 (only EPSON mode).*  
**1B 3E**  
**27 62**

This command sets Most Significant Bit of each data as 1.

---

**ESC =**                    *Set the 8th bit of the byte to 0 (only EPSON mode).*  
**1B 3B**  
**27 61**

This command sets Most Significant Bit of each data as 0.

---

**ESC #**                    *Cancel Most Significant Bit control (only EPSON mode).*  
**1B 23**  
**27 35**

This command cancels the Most Significant Bit control set by ESC = or ESC > .

---

**ESC SP {n}**     *Sets intercharacter space (only EPSON mode).*

**1B 20 {n}**  
**27 32 {n}**  
**0 ≤ n ≤ 255**

This command sets the intercharacter space to n/120 inch in Draft and n/180 inch in Quality.

---

**ESC \$ {n} {m}**     *Sets absolute dot position (only EPSON mode).*

**1B 24 {n} {m}**  
**27 36 {n} {m}**  
**0 ≤ n, m ≤ 255**

The dot position is calculated as  $\{m\} * 256 + \{n\}$ .

---

**ESC \ {n} {m}**     *Sets relative dot position (only EPSON mode).*

**1B 5C {n} {m}**  
**27 92 {n} {m}**  
**0 ≤ n, m ≤ 255**

This command sets the relative dot position, so that the print head is moved to a dot position specified relative to its current position. The unit of the dot is 1/120 inch. The Right Side position is calculated as  $\{m\} * 256 + \{n\}$ . The Left Side position as  $65536 - \{m\} * 256 + \{n\}$ .

---

**ESC d {n} {m}**     *Spaces forwards relative dot position only (only IBM mode).*

**1B 64 {n} {m}**  
**27 100 {n} {m}**  
**0 ≤ n, m ≤ 255**

This command causes the print head to be moved to a dot position calculated as  $\{n + m * 256\} / 120$  inch on the right of its current dot position. If the selected position is outside the current right margin, it is forced to last column.

---

**ESC e {n} {m}***Spaces backwards relative dot position (only IBM mode).***1B 65 {n} {m}**  
**27 101 {n} {m}**  
**0 ≤ n, m ≤ 255**

This command causes the print head to be moved to a dot position calculated as  $\{n+m*256\}/120$  inch on the left of its current dot position. If the selected position is outside the current left margin, it is forced to first column.

---

**ESC [ \ {l} {h} {m1}...{m4}***Sets vertical units (only IBM mode).***1B 5B 5C {l} {h} {m1}...{m4} m1 = ignored**  
**27 91 92 {l} {h} {m1}...{m4} m2 = ignored**  
**l = 4 m3 = normally equal to 180**  
**h = 0 m4 = normally equal to 216**

This command sets the value of the vertical units.  $\{h\}*256+\{l\}$  is the number of bytes for this command. You can set the vertical units to 1/180 inch or 1/216 inch according to the following table:

<b>m3</b>	<b>m4</b>	<b>Vertical Units</b>
0	180	1/180 inch
180	0	1/180 inch

<b>m3</b>	<b>m4</b>	<b>Vertical Units</b>
0	216	1/216 inch
216	0	1/216 inch

---

**ESC j***Stops printing (only IBM mode).***1B 6A**  
**27 106**

Terminator code. It then causes the printing to be stopped and the buzzer to be so unded. The printer will be disabled to print, press the ON LINE/← key to put printer online. This command has the same effect by pressing the ON LINE/← key.



---

# Tables

---

This appendix contains selected character sets and the hexadecimal to decimal conversion table.

<b>Character Sets .....</b>	<b>B.2</b>
Character Set 1 (CS1) .....	B.2
Character Set 2 (CS2) .....	B.3
IBM PC Character Set (All Printable Character Table).....	B.4
IBM National Variations .....	B.5
EPSON National Variations .....	B.10
Hexadecimal to Decimal Conversion Table .....	B.11

# Character Sets

## Character Set 1 (CS1)

---

	00	10	20	30	40	50	60	70	80	90	A0	B0	C0	D0	E0	F0
00	NUL		SP	0	@	P	`	p	NUL		á	â	ã	ä	å	æ
01		DC1	!	1	A	Q	a	q		DC1	í	î	ï	ª	»	±
02		DC2	"	2	B	R	b	r		DC2	ó	ô	õ	¶	·	¸
03		DC3	#	3	C	S	c	s		DC3	ú	û	ü			
04		DC4	\$	4	D	T	d	t		DC4	ñ					
05			%	5	E	U	e	u								
06			&	6	F	V	f	v								¡
07	BEL		'	7	G	W	g	w	BEL		¢	£	¤	¥	¦	§
08	BS	CAN	(	8	H	X	h	x	BS	CAN	¨	©	ª	«	¬	­
09	HT		)	9	I	Y	i	y	HT		®	¯	°	±	²	³
0A	LF		*	:	J	Z	j	z	LF		´	µ	¶	·	¸	¹
0B	VT	ESC	+	;	K	[	k	{	VT	ESC	º	»	¼	½	¾	¿
0C	FF		,	<	L	\	l		FF		¸	¸	¸	¸	¸	¸
0D	CR		-	=	M	]	m	}	CR		¸	¸	¸	¸	¸	¸
0E	SO		.	>	N	^	n	~	SO		¸	¸	¸	¸	¸	¸
0F	SI		/	?	O	_	o	DEL	SI		¸	¸	¸	¸	¸	¸

## Character Set 2 (CS2)

	00	10	20	30	40	50	60	70	80	90	A0	B0	C0	D0	E0	F0
00	NUL		SP	0	@	P	`	p	Ç	æ	á	⌘	⌘	⌘	α	≡
01		DC1	!	1	A	Q	a	q	ü	æ	í	⌘	⌘	⌘	β	±
02		DC2	"	2	B	R	b	r	é	Æ	ó	⌘	⌘	⌘	Γ	≥
03	♥	DC3	#	3	C	S	c	s	à	ò	ú			⌘	π	≤
04	♦	DC4	\$	4	D	T	d	t	ä	ö	ñ		-	⌘	Σ	∫
05	♣	§	%	5	E	U	e	u	à	ò	ñ		+	⌘	σ	∫
06	♠		&	6	F	V	f	v	a	û	ä			⌘	μ	÷
07	BEL		'	7	G	W	g	w	ç	ù	ø	⌘	⌘	⌘	τ	≈
08	BS	CAN	(	8	H	X	h	x	ê	ÿ	¿	⌘	⌘	⌘	Φ	°
09	HT		)	9	I	Y	i	y	è	ö	⌘	⌘	⌘	⌘	Θ	•
0A	LF		*	:	J	Z	j	z	é	ù	⌘	⌘	⌘	⌘	Ω	·
0B	VT	ESC	+	;	K	[	k	{	ï	ç	½	⌘	⌘	⌘	δ	√
0C	FF		,	<	L	\	l		í	£	¼	⌘	⌘	⌘	∞	∞
0D	CR		-	=	M	]	m	}	ï	¥	;	⌘	=	⌘	∅	²
0E	SO		.	>	N	^	n	~	Å	¤	«	⌘	⌘	⌘	ε	■
0F	SI		/	?	O	_	o	DEL	Å	ƒ	»	⌘	⌘	⌘	∩	SP

**IBM PC Character Set (All Printable Character Table)**

	00	10	20	30	40	50	60	70	80	90	A0	B0	C0	D0	E0	F0
00	ø	►		0	@	P	`	p	ç	é	á	☼	ℓ	⊥	α	≡
01	⊗	◄	!	1	A	Q	a	q	ü	æ	í	☼	⊥	⌊	β	±
02	⊕	↑	"	2	B	R	b	r	é	Æ	ó	☼	⌊	⌊	Γ	≥
03	♥	!!	#	3	C	S	c	s	â	ô	ú		⌊	⌊	π	≤
04	♦	Π	\$	4	D	T	d	t	ä	ö	ñ	⌊	—	⌊	Σ	∫
05	♣	§	%	5	E	U	e	u	à	ò	ñ	⌊	⌊	⌊	σ	∫
06	♣	_	&	6	F	V	f	v	á	û	ä	⌊	⌊	⌊	μ	÷
07	•	ì	'	7	G	W	g	w	ç	ù	ø	⌊	⌊	⌊	τ	≈
08	▣	†	(	8	H	X	h	x	è	ÿ	¿	⌊	⌊	⌊	ϕ	°
09	◦	↓	)	9	I	Y	i	y	ë	ö	⌊	⌊	⌊	⌊	θ	•
0A	▣	→	*	:	J	Z	j	z	è	ù	⌊	⌊	⌊	⌊	Ω	•
0B	♂	←	+	;	K	[	k	{	í	ç	½	⌊	⌊	■	ó	√
0C	♀	⌊	,	<	L	\	l		í	é	¼	⌊	⌊	■	∞	∞
0D	♂	↔	—	=	M	]	m	}	í	¥	;	⌊	=	■	ø	²
0E	♂	▲	.	>	N	^	n	~	À	⌊	«	⌊	⌊	■	ε	■
0F	*	▼	/	?	O	_	o	ó	À	ç	»	⌊	⌊	■	∩	

# IBM National Variations

## USA (CP 437)

	00	10	20	30	40	50	60	70	80	90	AO	BO	CO	DO	EO	FO
00	ø	▶	0	@	P	`	p	ç	É	á	⋮	L	ll	α	≡	
01	©	◀	!	1	A	Q	a	q	ü	æ	í	⋮	⊥	⊔	β	±
02	•	‡	"	2	B	R	b	r	é	ï	ó	⋮	⊔	⊔	Γ	≥
03	♥	!!	#	3	C	S	c	s	â	ô	ú			ll	π	≤
04	♦	¶	\$	4	D	T	d	t	ä	ö	ñ		-	⊥	Σ	∫
05	♣	§	%	5	E	U	e	u	à	ò	ñ		†	F	σ	J
06	♠	_	&	6	F	V	f	v	â	û	ä			⊔	μ	+
07	•	‡	'	7	G	W	g	w	ç	ù	ó	⊔			τ	≈
08	□	†	(	8	H	X	h	x	ê	ÿ	¿	⊔	⊥	φ	°	
09	○	‡	)	9	I	Y	i	y	ë	Ö	∩		⊔	J	θ	.
0A	■	→	*	:	J	Z	j	z	è	Ü	∩		⊥	∫	Ω	.
0B	♂	←	+	;	K	[	k	{	ï	ç	½	⊔	⊔	■	ó	∫
0C	♀	⊥	,	<	L	\	l		î	é	¼			■	∞	n
0D	›	↔	-	=	M	]	m	}	ï	¥	ı	ll	=		φ	z
0E	β	▲	.	>	N	^	n	~	Ä	Œ	«				ε	■
0F	*	▼	/	?	O	_	o	△	Å	f	»	⊔	⊥	■	∩	

## Multilingual (CP 850)

	00	10	20	30	40	50	60	70	80	90	A0	B0	C0	D0	E0	F0
00	ø	▶	0	@	P	·	p	Ç	É	á	⋮	Ł	ø	Ó	-	
01	©	◀	!	1	À	Q	a	q	ü	æ	í	⋮	±	Ð	ß	±
02	•	†	"	2	B	R	b	r	é	È	ó	⋮	Ť	Ê	Ô	—
03	♥	!!	#	3	C	S	c	s	â	ô	ú		†	Ë	Ò	×
04	♦	¶	§	4	D	T	d	t	ä	ö	ñ		-	È	ø	¶
05	♣	§	%	5	E	U	e	u	à	ò	ñ	Á	†	ı	Ö	§
06	♣	-	&	6	F	V	f	v	á	ú	ä	Å	ä	í	μ	÷
07	·	ı	'	7	G	W	g	w	ç	ù	ø	À	Å	İ	þ	,
08	□	†	(	8	H	X	h	x	ê	ÿ	ı	©	Ł	İ	þ	°
09	○	ı	)	9	I	Y	i	y	ë	Ö	•	Ť	Ť	ı	Ú	..
0A	■	→	*	:	J	Z	j	z	è	Ü	~		±	Ť	0	·
0B	♂	←	+	;	K	[	k	{	ï	ø	½	Ť	Ť	■	Ù	ı
0C	♀	↳	,	<	L	\	l		ı	£	¼	Ť	Ť	■	Ý	³
0D	›	↔	-	=	M	]	m	}	ı	ø	ı	©	=	ı	Ý	²
0E	ß	▲	.	>	N	^	n	~	Ä	×	α	¥	Ť	ı	-	■
0F	×	▼	/	?	O	_	o	o	Å	ƒ	»	Ť	■	ı	ı	ı

## Portugal (CP 860)

	00	10	20	30	40	50	60	70	80	90	AO	BO	CO	DO	EO	FO
00	ø	▶		0	@	P	`	p	Ç	É	Á	⋮	L	ll	α	≡
01	ø	◀	!	1	A	Q	a	q	ü	À	í	⋮	l	ƒ	β	±
02	●	†	"	2	B	R	b	r	é	È	ó	≡	T	ff	Γ	z
03	♥	!!	#	3	C	S	c	s	à	ò	ú		†	ll	κ	z
04	♦	π	\$	4	D	T	d	t	ã	õ	ñ		-	ε	Σ	ƒ
05	♣	\$	%	5	E	U	e	u	à	ò	ñ	†	†	ƒ	σ	J
06	♠	-	&	6	F	V	f	v	Á	Ú	ã		†	ff	μ	+
07	•	í	'	7	G	W	g	w	ç	ù	ê	ff	ff	ff	τ	≈
08	□	†	(	8	H	X	h	x	ê	î	z	†	ll	†	φ	°
09	○	í	)	9	I	Y	i	y	Ê	Ô	Ò		ff	J	ø	.
0A	■	→	*	:	J	Z	j	z	è	Ü	~		ll	ƒ	Ω	.
0B	♠	←	+	;	K	[	k	{	í	ç	½	ff	ff	■	ó	√
0C	♀	L	,	<	L	\	l		Ô	É	¼	ff	ff	■	∞	n
0D	♣	↔	-	=	M	]	m	}	i	Ù	i	ll	=		ø	z
0E	♠	▲	.	>	N	^	n	~	Ã	®	«	†	ff		ε	■
0F	✱	▼	/	?	O	_	o	o	Ã	Ó	»	†	±	■	∩	

## Canada/France (CP 863)

	00	10	20	30	40	50	60	70	80	90	A0	B0	C0	D0	E0	F0
00	ø	▶		0	@	P	`	p	Ç	É	!	⋮	L	♠	α	≡
01	⊕	◀	!	1	À	Q	a	q	ü	È	´	⋮	⊥	⌈	β	±
02	⊙	†	"	2	B	R	b	r	é	Ê	ó	⋮	⌈	⌈	Γ	≥
03	♥	!!	#	3	C	S	c	s	à	ô	ú		⌈	⌈	π	≤
04	♠	π	\$	4	D	T	d	t	Å	Ë	¨		-	⌈	Σ	†
05	♣	S	%	5	E	U	e	u	à	ï	,	⌈	†	⌈	σ	J
06	♣	-	&	6	F	V	f	v	π	à	³	⌈	⌈	⌈	μ	÷
07	•	i	'	7	G	W	g	w	ç	ù	-	⌈	⌈	⌈	τ	≈
08	□	†	(	8	H	X	h	x	è	ı	ı	⌈	⌈	⌈	⊕	°
09	○	↓	)	9	I	Y	i	y	ë	ö	ı	⌈	⌈	⌈	⊙	•
0A	■	→	*	:	J	Z	j	z	ê	Û	-	⌈	⌈	⌈	Ω	•
0B	♂	←	+	;	K	[	k	{	ı	ç	½	⌈	⌈	■	ó	√
0C	♀	L	,	<	L	\	l	ı	é	κ	♠	⌈	⌈	■	∞	n
0D	♪	↔	-	=	M	]	m	}	=	Û	κ	♠	=	■	ø	²
0E	♠	▲	.	>	N	^	n	~	À	Ù	«	⌈	⌈	■	ε	■
0F	✱	▼	/	?	O	_	o	△	S	f	»	⌈	⌈	■	π	∩

## Denmark/Norway (CP 865)

	00	10	20	30	40	50	60	70	80	90	A0	B0	C0	D0	E0	F0
00	ø	▶		0	@	P	`	p	ç	É	Á	⋮	L	ll	α	≡
01	⊙	◀	!	1	À	Q	a	q	ü	æ	í	⋮	⊥	⌈	β	±
02	⊙	‡	"	2	B	R	b	r	é	Æ	ó	⋮	⌈	⌈	Γ	≥
03	♥	!!	#	3	C	S	c	s	à	ô	ú		†	ll	π	≤
04	♠	π	§	4	D	T	d	t	ä	ö	ñ	†	-	⊥	Σ	∫
05	♠	S	%	5	E	U	e	u	à	ò	Ñ	†	†	F	σ	J
06	♠	-	&	6	F	V	f	v	á	ú	ä		†	π	μ	÷
07	•	i	'	7	G	W	g	w	ç	ù	ó				τ	≈
08	□	†	(	8	H	X	h	x	ë	ÿ	¿	†	⊥	†	⊙	°
09	○	†	)	9	I	Y	i	y	ë	Ö	∩			J	⊙	•
0A	■	→	*	:	J	Z	j	z	è	Ü	∩		⊥	†	∞	•
0B	♂	←	+	;	K	[	k	{	i	ø	½		⌈	■	ó	√
0C	♀	⊥	,	<	L	\	l	l	í	£	¼			■	∞	n
0D	♂	↔	-	=	M	]	m	}	i	ø	i		=		ø	²
0E	♂	▲	.	>	N	^	n	~	Ä	Ⓡ	«	†			ε	■
0F	※	▼	/	?	O	_	o	o	Å	ƒ	¤	†	⊥	■	∩	

## EPSON National Variations

	35	36	60	62	64	91	92	93	94	96	105	123	124	125	126	(dec.)
USA	#	\$	<	>	@	[	\	]	^	`	i	{		}	~	
FRANCE	#	\$	<	>	à	°	ç	§	^	`	i	é	ù	è	''	
GERMANY	#	\$	<	>	§	À	Ö	Ü	^	`	i	ä	ö	ü	ß	
UNITED KINGDOM	£	\$	<	>	@	[	\	]	^	`	i	{		}	~	
DENMARK-1	#	\$	<	>	@	Æ	Ø	Å	^	`	i	æ	ø	å	~	
SWEDEN	#	¤	<	>	Æ	Å	Ö	Å	Ü	é	i	ä	ö	å	ü	
ITALY	#	\$	<	>	@	°	\	é	^	`	ù	i	à	ò	è	i
SPAIN-1	¢	\$	<	>	@	;	Ñ	¿	^	`	i	''	ñ	}	~	
JAPAN	#	\$	<	>	@	[	¥	]	^	`	i	{		}	~	
NORWAY	#	¤	<	>	Æ	Æ	Ø	Å	Ü	é	i	æ	ø	å	ü	
DENMARK-2	#	\$	<	>	Æ	Æ	Ø	Å	Ü	é	i	æ	ø	å	ü	
SPAIN-2	#	\$	<	>	á	;	Ñ	¿	é	`	i	í	ñ	ó	ú	
LATIN AMERICA	#	\$	<	>	á	;	Ñ	¿	é	ü	i	í	ñ	ó	ú	

## Hexadecimal to Decimal Conversion Table

	00	10	20	30	40	50	60	70	80	90	A0	B0	C0	D0	E0	F0
00	0	16	32	48	64	80	96	112	128	144	160	176	192	208	224	240
01	1	17	33	49	65	81	97	113	129	145	161	177	193	209	225	241
02	2	18	34	50	66	82	98	114	130	146	162	178	194	210	226	242
03	3	19	35	51	67	83	99	115	131	147	163	179	195	211	227	243
04	4	20	36	52	68	84	100	116	132	148	164	180	196	212	228	244
05	5	21	37	53	69	85	101	117	133	149	165	181	197	213	229	245
06	6	22	38	54	70	86	102	118	134	150	166	182	198	214	230	246
07	7	23	39	55	71	87	103	119	135	151	167	183	199	215	231	247
08	8	24	40	56	72	88	104	120	136	152	168	184	200	216	232	248
09	9	25	41	57	73	89	105	121	137	153	169	185	201	217	233	249
0A	10	26	42	58	74	90	106	122	138	154	170	186	202	218	234	250
0B	11	27	43	59	75	91	107	123	139	155	171	187	203	219	235	251
0C	12	28	44	60	76	92	108	124	140	156	172	188	204	220	236	252
0D	13	29	45	61	77	93	109	125	141	157	173	189	205	221	237	253
0E	14	30	46	62	78	94	110	126	142	158	174	190	206	222	238	254
0F	15	31	47	63	79	95	111	127	143	159	175	191	207	223	239	255



---

# ***Interface***

---

This appendix provides technical information for the parallel and serial interfaces.

<i>Parallel Interface</i> .....	<i>C.2</i>
<i>Serial Interface</i> .....	<i>C.5</i>

## Parallel Interface

The parallel interface is an 8-bits per byte TTL-compatible interface. It uses 7- or 8-bit data transfer code without parity check. You can select the parallel interface via the Printer Setup procedure (see I/F function in Chapter 3).

- ◆ Drive Capability

Up to 15 feet (5 m) on AWG26 min. wire size of twisted conductors on TTL receiver.

- ◆ Printer Connector Type

AMPHENOL 57-40360-12-D56 or equivalent

- ◆ Cable Connector

AMPHENOL 57-30360-12 or equivalent Interface

- ◆ Signals

The interface pin assignment is described in the following table:

Signal Name	Pin Number		Source	Description
	Signal Wire	Return Wire		
$\overline{\text{STROBE}}$	1	19	HOST	Clock signal which controls data transmission.
DATA BIT 1	2	20	HOST	Represents transmitted data; logical "1" is represented by HIGH level signal. DATA BIT 1 (pin 2) is the least significant bit.
DATA BIT 2	3	21		
DATA BIT 3	4	22		
DATABIT 4	5	23		
DATA BIT 5	6	24		
DATA BIT 6	7	25		
DATA BIT 7	8	26		
DATA BIT 8	9	27		
$\overline{\text{ACK}}$	10	28	PRT	Active LOW level signal. Indicates that data has been received and stored in the buffer.
BUSY	11	29	PRT	An active HIGH level signal which indicates that the printer cannot accept data.

Signal Name	Pin Number		Source	Description
	Signal Wire	Return Wire		
PE	12	-	PRT	Active HIGH level. Indicates that a paper out (Paper Empty) condition has occurred.
SELECT	13	-	PRT	Active HIGH level. Indicates that the printer is ready to receive and print data.
<u>AUTOFEEDXT</u>	14	-	HOST	Active LOW level (EPSON mode only). Indicates an automatic LF after a CR.
NC	15	-	-	Not used.
GND	-	16,33	-	Common ground signal.
CHASSIS GROUND	-	17	-	Frame ground.
NC	18	-	-	Not used
GND	30	-	-	Common ground signal
INIT	31	30	HOST	Active LOW level. Causes the printer to initialize.
<u>ERROR</u>	32	-	PRT	Active LOW level. Indicates that the printer is disabled because of a paper out condition or printer malfunction.
NC	33	-	-	Not used
NC	34	-	-	Not used.
+5VDC	35	-	PRT	Pulled up signal.(33 k ohm).

Signal Name	Pin Number	Signal Return Wire	Source	Description
$\overline{\text{SELECTIN}}$	36	-	HOST	Active HIGH level. Indicates that it is possible the data entry control. Internal set is determined by the SLCT IN function

---

## *Serial Interface*

This printer provides a RS-232/C serial interface. You can select it via the Printer Setup procedure (see I/F function in Chapter 3). The remote or local connection can be used with all its control signals.

- ◆ Transmission Type

Data is sent and received in start/stop (asynchronous) transmission.

- ◆ Character Format

Each character is transmitted in the following format:

1 START BIT + 7 or 8 DATA BITS + 1 PARITY BIT (if present) + 1 STOP BIT

The least significant bit of the data bits is sent first after the start bit. The number of data bits is selected by the Printer Setup procedure (see DATA BITS function, in . The parity bit, when present, follows the data bits. The start bit is a logical "0" and the stop bit is a logical "1". The start and stop bits are used as character framing bits.

- ◆ Drive Capability

RS-232/C: up to 50 feet (15 m)

- ◆ Printer Connector

ANSLEY 609-25S or equivalent connector with 25 female contacts and male shell.

- ◆ Cable Connector

AMP 205208/1 or equivalent connector with 25 male contacts and female shell.

- ◆ Interface Signals

This table lists the RS-232/C interface signals (Data RDY/BSY System):

<b>Signal Name</b>	<b>Pin Number</b>	<b>Source Local Connect.</b>	<b>Remote Connect.</b>	<b>Description</b>
FRAME GND	1		-	The printer is shipped with pin 1 connected to the frame ground (protective ground).
TXD	2	PRT	PRT	Not used.
RXD	3	HOST	D A T A SET	Receive data.
GND	7	-	-	This pin is the common ground signal.
$\overline{\text{ERROR}}$	14	-	PRT	Active LOW level. Indicates that the printer is disabled because of a paper out condition or printer malfunction.
DTR	20	PRT	PRT	Normally HIGH (ON). With hardware data flow selected.

This table lists the RS-232/C interface signal (XON/XOFF System):

<b>Signal Name</b>	<b>Pin Number</b>	<b>Source Local Connect.</b>	<b>Remote Connect.</b>	<b>Description</b>
FRAME GND	1		-	The printer is shipped with pin 1 connected to the frame ground (protective ground).
TXD	2	PRT	PRT	Used to transmit data
RXD	3	HOST	DATA SET	Used to receive data.
RTS	4	PRT	PRT	Active HIGH (ON) level signal. It is held ON until the printer is disconnected.
CTS	5	HOST	DATA SET	Active HIGH (ON) level signal. Indicates that the host or data set is ready to receive data from the printer.

<b>Signal Name</b>	<b>Pin Number</b>	<b>Source Local Connect.</b>	<b>Remote Connect.</b>	<b>Description</b>
DSR	6	HOST	DATA SET	Active HIGH (ON) level signal. Indicates that the host or data set is connected to the printer and is ready for data transfer.
GND	7	-	-	This pin is the common ground signal.
DCD	8	HOST	DATA SET	Active HIGH (ON) level signal. Indicates that the host is transmitting or the data set is receiving the Data Carrier signal.
$\overline{\text{ERROR}}$	14	-	PRT	Active LOW level. Indicates that the printer is disabled because of a paper out condition or printer malfunction.
DTR	20	PRT	PRT	Normally HIGH (ON). With hardware data flow selected



# **Glossary**

This appendix is a glossary that contains explanations of unfamiliar terms regarding the printer.

*Glossary.....D.2*

## **ASCII**

American Standard Code for Information Interchange. A standard code used to represent characters in 8-bit code to allow communication between the computer and another type of device.

## **AUTOMATIC SHEET FEEDER (ASF)**

Equipment that automatically loads single sheets into the printer.

## **BAUD RATE**

Baud rate is the rate at which information is transferred between the computer and the printer. Baud is a unit of transmission speed based upon the number of signals per second. The computer and the printer must be configured at the same baud rate for the communication to function correctly.

## **BIDIRECTIONAL PRINTING**

The print head moves from left to right on one line and from right to left on the next line. In this way, the speed of printing is optimized.

## **BIT**

Contraction of binary digit. A bit represents "0" or "1" (ON or OFF) and it is the smallest unit of digital information used by the computer or any peripheral device.

## **BPS**

Abbreviation for bit per second.

## **BUFFER**

An area of memory in the computer or printer where the data is stored until it can be processed.

## **BYTE**

A byte represents a unit of information consisting of eight bits.

## **CARRIAGE RETURN**

A control code which causes the printer carriage to be moved to its leftmost position.

## **CHARACTER SET**

A set containing related characters. A set, for example, may be composed of math symbols, or characters in foreign language and so on.

## **COMPRESSED**

Printing is considered compressed when the horizontal spacing is set to 17 cpi (characters per inch).

## **CONTROL CODE**

A given instruction that will cause the printer to perform a certain function.

## **CPI**

Characters per inch. This is a unit to measure horizontal spacing.

## **CPS**

Characters per second. This is a unit used to measure the rate of printing.

**DECIMAL**

This represents an ASCII character put into the decimal form equal to its 7- or 8-bit binary code.

**DEFAULT**

A value which has been set to be active when the printer is turned on and/or when the printer is reinitialized by software.

**DOT GRAPHICS**

A drawing created by dot matrix.

**DOT MATRIX**

Printing method in which groups of dots are used to compose symbols.

**DOUBLE STRIKE**

Printing attribute. The character is printed twice in the same position with a vertical displacement of 1/180 inch in the second pass.

**DOUBLE WIDTH**

Printing attribute. The character is printed within a double space. It is also called enlarged.

**DOWN-LINE LOADING**

A method to define new characters through the use of specific commands which are sent to the device (printer).

**DPI**

Dots per inch. This is the unit of measurement used for dot graphics.

**DRAFT**

A type of high speed printing.

**EMPHASIZED**

Printing attribute. The character is printed twice with the smallest possible displacement between positions.

**ESCAPE SEQUENCE**

A sequence of control characters that starts with ESC code and are used to call up certain attributes of the printer such as double strike.

**FANFOLD PAPER**

A type of paper which is perforated and which has vertical strips with sprocket holes.

**FONT**

A set of characters with a given size and style.

**FORM FEED**

Control code and function key on the operator panel. Form Feed prints the stored data from the printer's memory which will control the page break attributes of the printer.

**HARDWARE**

The physical equipment.

**HEX DUMP**

A procedure to help the user specify the errors in the data string that had created the system problems.

## **HEXADECIMAL**

The numbers are represented to the base 16. The digits range from 0 to 9 and then from A to F in hexadecimal symbols are used in programming because they are compact.

## **HORIZONTAL SPACING**

Horizontal spacing is the spacing reserved for each character. There are two types of spacing: fixed and proportional. With fixed spacing the amount of space available for the characters will remain the same during the printing session. There is a wide range of measurements available for horizontal spacing: 10, 12, 15, 16.7, 17.1 cpi (characters per inch). With proportional spacing, the space assigned to the character varies according to the character width.

## **INTERFACE**

With regard to hardware: interface refers to the connection, i.e. the board between the host and the printer. With regard to software: interface refers to the standards which are set relating to the communication between the host and the printer.

## **ITALICS**

Printing attribute. The characters shapes are slanted.

## **LINE FEED**

Control code and function key that will cause the printer to advance to the next line.

## **MEMORY**

The printer, like the computer has a memory. When you want to print a file, the information will be quickly sent to the printer's memory and from there it will be printed onto paper.

## **NEEDLES**

They are an essential part of the print head which will cause a particular dot group to be printed on the paper to represent a graphics symbol character.

## **OPERATOR PANEL**

With the indicators, function keys (which could be buttons or touch-sensitive buttons) and the display, the user can control the operation of the printer.

## **PAGE FORMATTING**

A parameter which allows the information to be correctly arranged on the page. Using this parameter, you can set the top, bottom, left and right margins, the text length, the horizontal and vertical spacings and so on.

## **PAPER BAIL**

The bar that holds the paper against the platen.

## **PLATEN KNOB**

Used to load paper. After turning the printer on, the user feeds the paper by pulling the lever. When the paper has been correctly positioned, the user releases the lever.

## **PAPER OUT SENSOR**

This sensor will send a signal when there is no more paper. This will cause the printer to stop printing.

## **GAP SET LEVER**

Used to adjust the distance between print head and platen such that the user can load different types of paper into the printer (for example multipart form).

**POWER CABLE**

This is the cable which effects the connection between the computer and the main power supply.

**PRINT HEAD**

The mechanism that moves horizontally along the carriage bar to execute the printing.

**PROPORTIONAL PRINTING**

This type of printing will assign a space to the character such that it is proportional to the character width.

**QUALITY**

A type of printing whose quality is quite high due to the increased number of dots which make up a character. As a result, the printing speed is reduced.

**RAM**

Random Access Memory

**ROM**

Read Only Memory

**SINGLE SHEET**

This is the type of paper that must be loaded into the printer one sheet at a time. You can handle large quantities of single sheets using the Automatic Sheet Feeder.

**SOFTWARE**

The set of instructions which are sent to the printer to perform certain functions.

**TRACTORS**

The tractor unit is mechanism which allows the fanfold paper to be fed.

**VERTICAL SPACING**

It is the distance between two lines.

